



BLACKMAX[®] TECHNICAL GUIDE

Polypropylene Structured Wall Pipe Systems
for Stormwater drainage applications

June 2025



IMPORTANT DISCLAIMER

This document provides technical information about the BlackMax product range. It is subject to change without notice. Iplex does not provide design or other professional services and this document must not be relied upon as such. Before purchasing goods, always seek independent expert advice on the suitability of the goods for the intended purpose or their application. Any safety information is provided as a guide only and any reliance on or use of any such information is at your own risk. Except as provided in Iplex's terms and conditions of sale for these goods, and to the extent permitted by law, Iplex is not liable for any direct or indirect loss, damage or injury suffered by persons who rely on the information contained in this document. The designs, graphics, logos, trademarks (including BlackMax, Iplex Pipelines® and Iplex®) and other intellectual property contained in this document are owned by or licensed to Iplex and you must not use, reproduce, or otherwise deal with the content without Iplex's prior written consent.

**COPYRIGHT® 2025. ALL RIGHTS RESERVED.
IPLEX PIPELINES AUSTRALIA PTY LIMITED ABN 56 079 613 308**



CONTENTS

1.0 INTRODUCTION	6
1.1 MANUFACTURE	7
1.2 PRODUCT FEATURES	8
1.3 APPLICATIONS	9
2.0 PRODUCT DATA	10
2.1 MATERIAL PROPERTIES	10
2.2 STANDARDS	11
2.3 SERVICE EXPECTANCY	12
2.3.1 ENVIRONMENTAL PRODUCT DECLARATION	12
2.3.2 CHEMICAL RESISTANCE	13
2.3.3 RESISTANCE TO MICROBIOLOGICAL ATTACK	13
2.3.4 RESISTANCE TO SUNLIGHT	13
2.3.5 ABRASION RESISTANCE	13
2.3.6 OXIDATION	13
2.3.7 CORROSION	13
2.4 BLACKMAX PIPE RANGE	14
2.4.1 BLACKMAX FITTINGS	16
2.4.2 BLACKMAX FITTINGS RANGE	17
2.4.3 SADDLES	28
2.4.4 FERNCO® SADDLES	29
2.4.5 BLACKMAX STAINLESS STEEL CLAMPS	31
2.4.6 FERNCO® SHEAR BANDED COUPLINGS (BLACKMAX DN225 TO DN1200)	32
2.5 PIPE JOINTING	33
2.5.1 JOINT CROSS SECTION DETAILS	33
2.5.2 RUBBER RING JOINT DESIGN AND PERFORMANCE	34
2.5.3 JOINT TIGHTNESS TESTS	35
2.5.4 PRESSURE AND VACUUM	35
2.6 PIPE STIFFNESS	35
2.7 RING FLEXIBILITY	35
3.0 DESIGN	36
3.1 HYDRAULIC PERFORMANCE	36
3.1.1 STORMWATER DRAINAGE DESIGN	42
3.1.2 VELOCITIES IN STORMWATER DRAINAGE PIPELINES - GENERAL	42
3.1.3 HIGH VELOCITIES	43
3.2 STRUCTURAL DESIGN	45

3.2.1	GEOTECHNICAL INVESTIGATION	47
3.2.2	DERIVATION OF SOIL DEFORMATION MODULUS VALUES	47
3.2.3	EFFECTIVE SOIL MODULUS	50
3.2.4	EFFECTS OF CONSTRUCTION LOADS ON BURIED BLACKMAX (PP) PIPES	54
4.0	INSTALLATION	55
4.1	PLANNING	55
4.2	TRANSPORTATION AND STORAGE	55
4.3	UNLOADING	55
4.4	HANDLING	56
4.5	INSTALLATION GUIDELINES	57
4.6	EXCAVATION AND ASSOCIATED WORKS	57
4.6.1	TRENCH EXCAVATION	57
4.6.2	FOUNDATION	57
4.6.3	UNSTABLE AND WET GROUND CONDITIONS	57
4.6.4	TRENCH SHIELDS	58
4.7	PIPE LAYING	59
4.7.1	BEDDING	59
4.7.2	JOINTING OF PIPES	59
4.8	PIPE SIDE SUPPORT AND OVERLAY	61
4.8.1	EMBEDMENT - HAUNCHING AND SIDE SUPPORT	61
4.8.2	OVERLAY	62
4.9	TRENCH & EMBANKMENT FILL	62
4.9.1	MONITORING DIAMETRAL DEFLECTIONS	62
4.10	BORE CASING	62
4.10.1	GROUTING	63
4.11	JOINTING TO RIGID STRUCTURES	63
4.11.1	RELATIVE SETTLEMENT	63
4.11.2	CONNECTIONS FOR INCOMING SIDELINES (NON-PRESSURE)	64
4.12	REPAIR METHODS	64
4.12.1	FOR MINOR REPAIRS	64
4.12.2	MAJOR REPAIRS	65
4.12.3	MAJOR REPAIRS - FERNCO COUPLING	66
5.0	FIELD ACCEPTANCE TESTING	67
5.1	DEFLECTION TESTING	67



BlackMax pipe manufacturing process

1.0 INTRODUCTION

Iplex is a major Australian manufacturer and supplier of plastic pipes and fittings suitable for civil, plumbing, irrigation, industrial and mining applications. As a leader in plastic pipe technology, Iplex has continued to develop innovative products offering solutions for the demanding service and environmental needs of today. To meet these requirements, Iplex has introduced BlackMax for stormwater drainage and low head irrigation.

BlackMax is a cost-effective alternative to conventional pipe systems, with improved performance and exceptional durability. BlackMax is corrosion and abrasion resistant, which can limit the life of more conventional materials.

The profile wall structure provides an efficient use of material, producing a pipe with high ring stiffness and low mass. As a result, pipes are only a fraction of the weight of conventional materials and can readily withstand both installation and service loads.

BlackMax pipes are manufactured in standard sizes DN225 up to DN1200* in 3m and 6m nominal lengths and are classified as SN8.

*DN1000 coming soon – for more information contact Iplex.

1.1 MANUFACTURE

BlackMax pipes are manufactured using a combined continuous extrusion and vacuum moulding process. The polypropylene pipe wall structure is comprised of a solid smooth inner wall and profiled outer wall. The inner and outer walls are extruded simultaneously and fused together circumferentially at the trough of each corrugation. This wall construction results in a high-stiffness pipe with a smooth inner bore which can be cut and re-joined anywhere along its length.

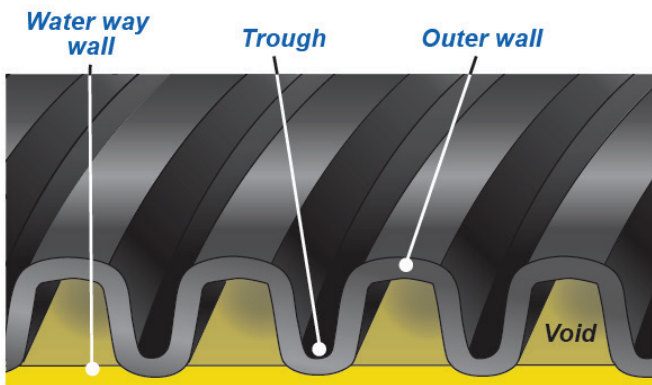

- BlackMax pipes with a black outer wall and yellow internal liner
- Pipe classification SN8
- Standard lengths 3m and 6m nominal

Figure 1.1 Cross section of BlackMax PP pipe wall structure

BlackMax pipes and fittings are manufactured to Australian and New Zealand Standard, AS/NZS 5065 'Polyethylene and polypropylene pipes and fittings for drainage and sewerage applications' and carry StandardsMark and WaterMark third party product certifications under this standard.

A range of fittings is available for use with BlackMax pipes providing a complete corrosion resistant pipe system. Fittings are moulded or fabricated from PP or PVC-U pipe sections.



Prefabricated BlackMax bends ready for despatch

1.2 PRODUCT FEATURES

Throughout Australia, BlackMax has been chosen for its unique characteristics, material properties and benefits.

1. RESISTANCE TO CHEMICAL ATTACK

Polypropylene is known for its durability and resistance to various chemicals, making it suitable for environments with acid sulphate soils or areas with high salinity in groundwater. BlackMax can resist such conditions to ensure the longevity and effectiveness of underground piping systems.

2. RESISTANCE TO ABRASION

Polypropylene's resistance to abrasion makes it an excellent choice for stormwater drainage systems, especially in situations where high flow velocities are common. With its ability to withstand wear and tear, BlackMax pipes can maintain their integrity over time, minimizing the need for frequent maintenance or replacement due to damage from the high flow velocities. This durability helps ensure the effectiveness and longevity of stormwater drainage infrastructure.

3. LIGHTWEIGHT

The lightweight nature of BlackMax pipes compared to concrete pipes offers significant advantages, particularly during installation. Its light weight nature allows for easier handling and maneuverability in confined spaces, reducing the need for heavy lifting equipment. This not only enhances site efficiency but also contributes to cost savings by streamlining the installation process. Additionally, the ability to maneuver the pipes by hand or with light equipment can improve overall safety on the construction site.

4. LONG LENGTHS

The availability of BlackMax pipes in standard 3-meter and 6-meter nominal lengths offers flexibility and efficiency during trenching and installation. Contractors can choose the appropriate length based on the depth of the trench, optimizing laying rates for both shallow and deep trenching applications. This standardization simplifies planning and logistics for construction projects, contributing to overall efficiency and cost-effectiveness. Additionally, having standard lengths streamlines the assembly process, ensuring smooth and consistent installation of the piping system.

5. FLOW CHARACTERISTICS

The smooth bore of BlackMax pipes, coupled with their resistance to scale and sediment build-up, is advantageous

for hydraulic performance in piping systems. The smooth surfaces minimise frictional losses, allowing for efficient flow. This hydraulic efficiency can translate into several benefits, including increased capacity within the system, the potential for reduced grades (slope), or the ability to use smaller pipe sizes to achieve the desired flow rates. Overall, these characteristics contribute to improved system performance, potentially reducing construction costs and enhancing the overall effectiveness of the piping infrastructure.

6. IN-GROUND PERFORMANCE

The high tolerance to deformation exhibited by BlackMax pipes is a significant advantage, particularly in environments prone to soil movement or ground settlement. This resilience means that BlackMax pipes can resist external pressures and stresses without sustaining structural damage or cracking. In areas where soil movement is common, such as regions with expansive clay soils or areas subject to ground movement, this characteristic is invaluable. It helps ensure the integrity and longevity of the piping system, reducing the risk of leaks, breaks, or other failures even under challenging soil conditions. Overall, this feature contributes to the reliability and durability of BlackMax pipes in various installation scenarios.

7. TOUGHNESS

The tough, ductile nature of polypropylene is a key factor in enabling BlackMax pipes to resist accidental impact damage during transportation and handling on-site. Polypropylene's inherent flexibility and strength help the pipes withstand external forces, such as bumps or knocks, that may occur during transportation or while being maneuvered on-site. This resilience reduces the likelihood of damage, such as cracking or splitting, ensuring that the pipes remain structurally sound and intact upon installation. As a result, contractors can have confidence in the reliability and durability of BlackMax pipes throughout the construction process.

8. WEATHERING RESISTANCE

BlackMax pipes contain a minimum of 2.5% carbon black to enhance their durability, particularly when exposed to sunlight. Carbon black serves as a UV stabilizer, helping to protect the polypropylene material from degradation caused by prolonged exposure to sunlight. This additive acts as a barrier, absorbing and dispersing UV radiation, which can otherwise lead to material degradation, such as weakening

or embrittlement.

By incorporating carbon black into the pipes, BlackMax ensures that its products can withstand outdoor storage and exposure to sunlight without experiencing undue degradation. This feature is crucial for construction projects where pipes may need to be stored on-site before installation or where they will be exposed to sunlight during use. Overall, it enhances the longevity and performance of BlackMax pipes in various environmental conditions.

9. RUBBER RING JOINT

The design of the BlackMax rubber ring joint prioritizes ease of assembly and jointing, facilitating a streamlined installation

process. This design feature allows for efficient and secure connections between pipes, minimizing the time and effort required for jointing on-site. The rubber ring joint provides a reliable seal, ensuring leak-free performance once the pipes are connected.

Furthermore, the flexibility of BlackMax pipes enables them to be easily cut to the desired length anywhere along the pipe, providing flexibility for on-site adjustments. This capability allows contractors to customize the pipe lengths to fit specific project requirements without the need for specialized equipment or additional fittings. It adds to the versatility and convenience of working with BlackMax pipes, making them well-suited for a variety of installation scenarios and construction projects.

1.3 APPLICATIONS

The versatility of BlackMax pipes and fittings makes them suitable for a wide range of applications. The following applications are typical for BlackMax pipes and fittings:

- Stormwater drainage pipelines: BlackMax pipes are ideal for use in stormwater drainage systems, providing efficient conveyance of rainwater and runoff.
- Road culverts: These pipes can be used as culverts to channel water beneath roads and other transportation infrastructure, helping to manage water flow and prevent flooding.
- Low head irrigation: BlackMax pipes are suitable for irrigation systems with low pressure requirements, providing reliable water distribution to agricultural fields, and landscapes.
- Rehabilitation (as liner pipe): In rehabilitation projects, BlackMax pipes can serve as liner pipes within existing

infrastructure to reinforce or repair damaged pipelines.

- Leachate collection: These pipes can be used to collect leachate from landfill sites, ensuring proper containment and management of potentially harmful substances.
- Stormwater retention systems: BlackMax pipes can be incorporated into stormwater retention systems to capture and temporarily store excess rainwater, helping to mitigate the impact of heavy rainfall on urban areas.
- Estuarine and ocean outfalls: In marine environments, BlackMax pipes can be employed for outfall applications, facilitating the discharge of treated stormwater into estuaries or oceans.

Overall, the adaptability and robustness of BlackMax pipes and fittings make them a versatile choice for a diverse range of infrastructure and environmental projects.



BlackMax application examples

2.0 PRODUCT DATA

POLYPROPYLENE MATERIALS – GENERAL

Polypropylene is a high-quality material which has been used since the 1950's. Polypropylene's intrinsic properties of high stiffness, tensile strength and inertness towards acids, alkalis and solvents has secured its position in a wide range of industrial applications.

High impact resistance and stiffness combined with chemical resistance and temperature performance make polypropylene suitable for stormwater applications.

Polypropylene pipes such as BlackMax are resistant to abrasion making them suitable for a broad range of drainage and mining applications. The rate of abrasive wear of the pipe wall will be dependent upon the velocity and quantity of flow and the size and shape of the particles in stormwater

flow. In highway drainage, flow rates can vary from a few m/s to 7-10 m/s. Darmstadt abrasion tests* demonstrated polyolefin pipes had low abrasion compared with other materials due to their low surface roughness.

The smooth inner bore of BlackMax pipes allow excellent hydraulic capacity even at low gradients and helps prevent encrustation and pipe blockages.

2.1 MATERIAL PROPERTIES

BlackMax pipes are manufactured from block (heterophasic) copolymer polypropylene, which is a thermoplastic of the polyolefin group. Polypropylene is noted for its excellent chemical resistance, high modulus, and elevated temperature performance.

TABLE 2.1 Physical properties of BlackMax polypropylene pipes

Property	Value	Standard/Reference
Density of Pipe Compound	900 kg/m ³	ISO 1183
Ring Bending Modulus (3 mins)	1300 MPa	ISO 178
Creep ratio (2 years)	3	ISO 9967
Apparent Ring bending Modulus (2 years)	433 MPa	ISO 9967
Apparent Ring Bending Modulus (50 years)	342 MPa	ISO 9967
Pipe Ring Bending Stiffness - BlackMax	≥ 8000 N/m/m	AS/NZS 1462.22
Tensile Yield Stress (50mm/min)	31 MPa	ISO 527-2
Tensile Yield Strain (50mm/min)	8%	ISO 527-2
Poisson's Ratio	0.45	ISO 527-2
Thermal Co-efficient of Linear Expansion	15 X 10 ⁻⁵ / °C	DIN 53752
Shore D Hardness	60	ISO 868
Pipe - Allowable Long-Term Deflection	7.5%	AS/NZS 2566.1
Pipe - Allowable Short-Term Ring Bending Strain	4%	AS/NZS2566.1

*Borouge, Tech Note Abrasion resistant (TN 218 R)

2.2 STANDARDS

The following standards relate to the manufacture, testing, design, and installation of BlackMax pipes and fittings.

Standard

- AS/NZS 5065 'Polyethylene and polypropylene pipes and fittings for drainage and sewerage applications'

- EN13476 Plastics piping systems for non-pressure underground drainage and sewerage - Structured-wall piping systems of unplasticized poly(vinyl chloride) (PVC-U), polypropylene (PP) and polyethylene (PE) - Part 3: Specifications for pipes and fittings with smooth internal and profiled external surface and the system, Type B

- AS/NZS 1260 'PVC-U pipes and fittings for drain, waste, and vent applications' Section 3.4 Tests on elastomeric joints

- AS/NZS 1462.8 'Methods of test for plastics pipes and fittings Method 8: Method of testing the leak tightness of assemblies'

- AS/NZS 1462.10 'Methods of test for plastics pipes and fittings Method of hydrostatic pressure testing of fittings and elastomeric seal joints for non-pressure applications'

- AS/NZS 1462.13 'Methods of test for plastics pipes and fittings Method for the determination of elastomeric seal joint contact width and pressure'

- AS/NZS 1462.22 'Methods of test for plastics pipes and fittings Method for the determination of pipe stiffness'

- AS/NZ 1462.23 'Methods of test for plastic pipes and fittings: Method for determination of ring flexibility'

- AS 1646 'Elastomeric seals for waterworks purposes'

- AS 2200 'Design charts for water supply and sewerage'

- AS/NZS 2566.1 'Buried flexible pipelines - Part 1: Structural design'

- AS/NZS 2566.2 'Buried flexible pipelines - Part 2: Installation'

- AS/NZS 2033 Installation of Polyolefin pipe systems

- AS 4181 'Repair and off-take clamps for water industry purposes'

- ISO 9967 'Thermoplastics pipes – Determination of creep ratio'

- AS/NZS ISO 9001 'Quality management systems – requirements'

- ISO 14025 'Environmental labels and declarations – Type III environmental declarations – Principles and procedures'

- EN 15804 'Sustainability of construction works. Environmental product declarations. Core rules for the product category of construction products'



AS/NZS 5065



Quality
ISO 9001



WaterMark

AS/NZS 5065



2.3 SERVICE EXPECTANCY

In determining the life expectancy of a buried pipe, it is necessary to consider all the potential modes of failure and assess whether there is a real risk of the pipe failing by a mechanism under consideration. Polypropylene as a pipe material has been in existence over 50 years. Polypropylene is an inert material, will not readily abrade in service and is not affected by high or low pH soils or saltwater environments.

BlackMax pipes are manufactured from block copolymer polypropylene (PP-R). These components are designed to have a service life of more than 100 years. The 'greater-than-100-year' anticipated service life is based on the following:

- The convention applied by Iplex to the design of BlackMax is the same as used for many years in International (ISO), Australian and European (CEN) Standards for the design of plastics pipes. The design philosophy considers the visco-elastic behaviour of plastics together with the mechanical and chemical properties of the material.
- If installed, operated and maintained in accordance with the relevant product and installation standards and manufacturer's guides. The life expectancy is a guide only and may increase or decrease because of the system operating conditions, operating environment, and other geographical and site-specific factors.

2.3.1 ENVIRONMENTAL PRODUCT DECLARATION

An Environmental Product Declaration (EPD) is a standardised and verified way of quantifying the environmental impacts of a product based on a consistent set of rules known as PCR (Product Category Rules).

The Environmental Product Declaration* (EPD) for BlackMax polypropylene pipes:

- Conforms with International Standards ISO14025 and EN15804.
- Has been verified by an independent third party.
- Has at least a cradle to gate scope.
- Has product specific results.

The BlackMax polypropylene pipes EPD results can be used in Whole of life Cycle assessments under Green Star rating tools. Refer to the Tables in the BlackMax Environmental Product Declaration (EPD) to convert the product results from kilogram of installed pipe to length of pipe for individual pipe products.

* EPD currently applies to BlackMax polypropylene pipes manufactured in Brisbane.



2.3.2 CHEMICAL RESISTANCE

BlackMax pipes are made from a copolymer of polypropylene (PP-B). The elastomeric seals used to join the pipes are made from styrene butadiene rubber (SBR).

Polypropylene is inherently resistant to a wide range of chemicals such as acids, alkalis, salts, wetting agents, and alcohols.

SBR seals are also resistant to a wide range of chemicals such as salt solutions, alkalis, glycols, and some alcohols. Further reference and details about chemical resistance are available at iplex.com.au.

2.3.3 RESISTANCE TO MICROBIOLOGICAL ATTACK

There is no evidence microbiological attack is a potential failure mechanism for polypropylene pipes.*

2.3.4 RESISTANCE TO SUNLIGHT

BlackMax pipes contain a minimum of 2.5% carbon black for protection against UV radiation. These additives allow long-term storage of pipes in sunlight without degradation. Once buried, BlackMax pipes are not exposed to UV radiation and therefore will not degrade by this mechanism.

2.3.5 ABRASION RESISTANCE

Polypropylene is highly resistant to abrasion and is used for the conveyance of slurries with high solids content in mining and industrial applications. It is also selected for several mechanical and automotive applications such as linings for truck trays, spoilers, and bumpers for cars. Iplex examined PVC sewer pipes that had been in service for 26 years. There was no discernable loss in wall thickness due to abrasion. As polypropylene is accepted as having higher abrasion resistance than PVC, abrasion loss is an unlikely failure mode for BlackMax pipes.

2.3.6 OXIDATION

The polypropylene compound used for BlackMax pipes contains an antioxidant to protect against oxidation. Under normal ambient temperatures the level of protection is enough to provide more than 100 years service life when installed, operated and maintained in accordance with the relevant product and installation standards, and manufacturer's guides

2.3.7 CORROSION

Polypropylene, as with other plastics, is corrosion resistant.

*BlackMax Structured Wall Polypropylene pipes" 29.11.2004, Dr Alan Whittle PhD Senior scientist, Iplex Pipelines Australia Pty Ltd.



2.4 BLACKMAX PIPE RANGE

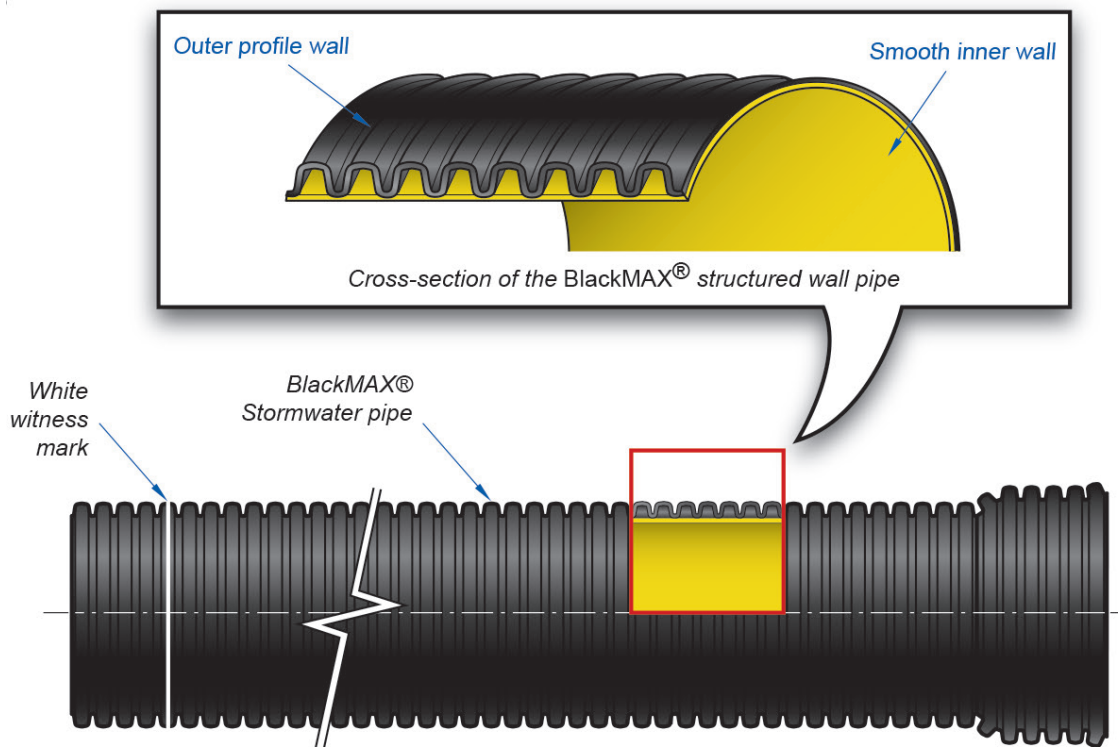

All images are indicative only and not to scale.

Application	Product Code	DN	SN	Nominal Length (m)	Colour Outer Wall	Colour Inner Wall					
Stormwater drainage	GR8225	225	8	6	Black	Yellow					
	GR8300	300									
	GR8375	375									
	GR8450	450									
	GR8525	525									
	GR8600	600									
	GR8750	750									
	GR8900	900									
	GR81000*	1000									
	GR81200	1200									
	Low head irrigation (non-pressure)	GR8225C					225	3 (subject to availability)			
		GR8300C					300				
GR8375C		375									
GR8450C		450									
GR8525C		525									
GR8600C		600									
GR8750C		750									
GR8900C		900									
GR81000C*		1000									
GR81200C		1200									

*DN1000 coming soon – for more information contact Iplex.

FIGURE 2.1 BlackMax Pipe – Longitudinal Cross-Section

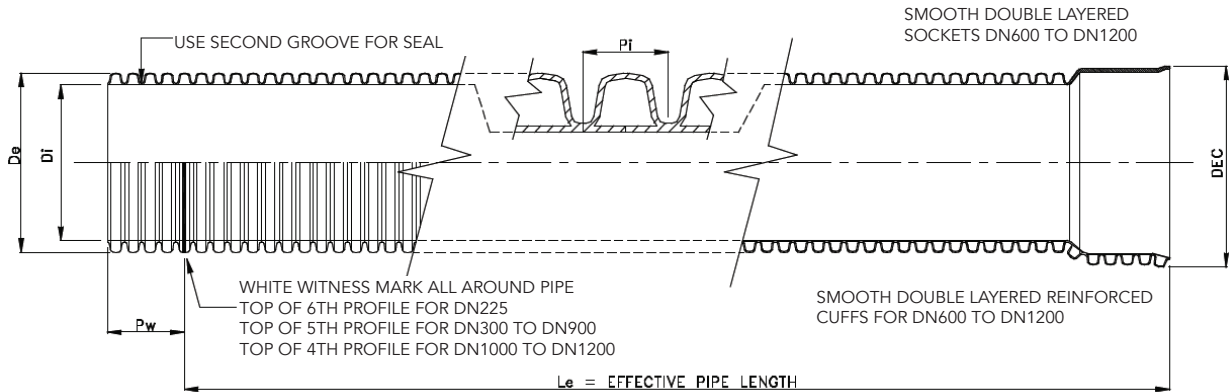

All images are indicative only and not to scale.

TABLE 2.2 BlackMax Pipe dimensions – SN8

DN	Mean Pipe OD De (mm)	Mean Pipe ID Di (mm)	Socket OD DEC (REF) (mm)	Mean Witness mark length Pw (mm)	Profile Pitch Pi (REF) (mm)	Approx. Pipe Barrel Mass (kg/m)	Effective Length Le Min (mm)
225	259	225	305	135	25	4	6000
300	344	300	403	147	33	6	6000
375	428	373	502	176	40	9	6000
450	514	447	603	222	50	13	6000
525	600	522	704	254	57	15	6000
600	682	596	750	296	66	21	5910
750	843	736	896	319	80	29	6000
900	1010	877	1072	398	100	39	6000
1000	1103	987	1187	TBC	TBC	TBC	TBC
1200	1342	1170	1432	476	133	73	5950



2.4.1 BLACKMAX FITTINGS



BlackMax PVC Saddle in manufacture



BlackMax PVC Junction in manufacture

A standard range of fittings for use with BlackMax pipes are available for a complete pipe system. Bends, tees, junctions, closed ends, couplings, plugs, reducers, saddles, and adaptors are fabricated with polypropylene BlackMax and PVC pipe sections.

BlackMax fittings comply with Australian Standard AS/NZS 5065 'Polyethylene and polypropylene pipes and fittings for drainage and sewerage applications'.

FITTINGS RANGE DN225 UP TO DN375 (SECTION 2.4.2)

Fittings for sizes DN225 to DN375 (Section 2.4.2) are fabricated with PVC pipe sections and moulded socket ends for rubber ring joint connection with BlackMax pipe spigots. All fittings are fibreglass reinforced and coloured black for identification.

FITTINGS RANGE DN450 UP TO DN1200 (SECTION 2.4.2)

BlackMax fittings in sizes DN450 to DN1200 are fabricated with BlackMax PP pipe sections. Fittings are generally supplied with socketed ends suitable for rubber ring connection with BlackMax pipe spigots. Other end configurations are also available, such as spigot ends with separate pipe couplings for jointing.

BlackMax fittings fabricated with dn100, dn150 or dn225 components are supplied with either PVC (RRJ or SWJ sockets) ends or standard solid wall polypropylene plain-ended pipe spigots (110mm OD) and (160mm OD). These components allow connections with PVC DWV pipes for stormwater drainage connections.

FITTINGS FOR REPAIRS (SECTION 2.4.2)

A range of stainless-steel clamps are available for pipe repairs and jointing. The clamps have been designed for use with BlackMax pipes and comply with Australian Standard AS 4181 'Repair and off-take clamps for water industry purposes.'

The stainless-steel clamps provide a quick and reliable solution for repairing damaged pipes. Clamps are manufactured from 316 stainless steel, with EPDM flat rubber matting (Joiner clamps) and moulded polyurethane rubber matting (Repair clamps). All welding is fully passivated to maintain the original state of the stainless steel for corrosion resistance.

2.4.2 BLACKMAX FITTINGS RANGE

BlackMAX Bends FF RRJ – DN225 to DN375* (Fabricated with PVC-U DWV Pipe Sections)

Product Code	Description	L (mm)
GWR0222511	DN225 x 11.25° BMax Bend RRJ F&F	TBC
GWR0230011	DN300 x 11.25° BMax Bend RRJ F&F	TBC
GWR0237511	DN375 x 11.25° BMax Bend RRJ F&F	TBC
GWR0222515	DN225 x 15° BMax Bend RRJ F&F	60
GWR0230015	DN300 x 15° BMax Bend RRJ F&F	125
GWR0237515	DN375 x 15° BMax Bend RRJ F&F	143
GWR0222522	DN225 x 22.5° BMax Bend RRJ F&F	TBC
GWR0230022	DN300 x 22.5° BMax Bend RRJ F&F	TBC
GWR0237522	DN375 x 22.5° BMax Bend RRJ F&F	TBC
GWR0222530	DN225 x 30° BMax Bend RRJ F&F	77
GWR0230030	DN300 x 30° BMax Bend RRJ F&F	147
GWR0237530	DN375 x 30° BMax Bend RRJ F&F	170
GWR0222545	DN225 x 45° BMax Bend RRJ F&F	96
GWR0230045	DN300 x 45° BMax Bend RRJ F&F	169
GWR0237545	DN375 x 45° BMax Bend RRJ F&F	200
GWR0222560	DN225x 60° BMax Bend RRJ F&F	TBC
GWR0230060	DN300x 60° BMax Bend RRJ F&F	TBC
GWR0237560	DN375 x 60° BMax Bend RRJ F&F	TBC
GWR0222590	DN225 x 90° BMax Bend RRJ F&F	204
GWR0230090	DN300 x 90° BMax Bend RRJ F&F	311
GWR0237590	DN375 x 90° BMax Bend RRJ F&F	373

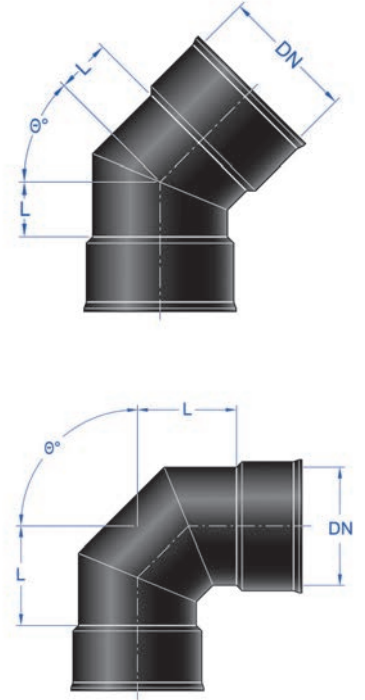

*Larger sizes are available on request

- Note:
- Other angles are available upon request.
 - BlackMax Bends are subject to availability at time of ordering.
 - Dimensions are approximate only.
 - All images are indicative only and not to scale.

BlackMax Bends FF RRJ – DN450 to DN600* (Fabricated with BlackMax PP Pipe Sections)

Product Code	Description	L (mm)
GR0245011	DN450 x 11.25° BMax Bend RRJ F&F	TBC
GR0252511	DN525 x 11.25° BMax Bend RRJ F&F	TBC
GR0260011	DN600 x 11.25° BMax Bend RRJ F&F	TBC
GR0245015	DN450 x 15° BMax Bend RRJ F&F	360
GR0252515	DN525 x 15° BMax Bend RRJ F&F	428
GR0260015	DN600 x 15° BMax Bend RRJ F&F	473
GR0245022	DN450 x 22.5° BMax Bend RRJ F&F	TBC
GR0252522	DN525 x 22.5° BMax Bend RRJ F&F	TBC
GR0260022	DN600 x 22.5° BMax Bend RRJ F&F	TBC
GR0245030	DN450 x 30° BMax Bend RRJ F&F	360
GR0252530	DN525 x 30° BMax Bend RRJ F&F	428
GR0260030	DN600 x 30° BMax Bend RRJ F&F	473
GR0245045	DN450 x 45° BMax Bend RRJ F&F	360
GR0252545	DN525 x 45° BMax Bend RRJ F&F	428
GR0260045	DN600 x 45° BMax Bend RRJ F&F	473
GR0245060	DN450 x 60° BMax Bend RRJ F&F	TBC
GR0252560	DN525 x 60° BMax Bend RRJ F&F	TBC
GR0260060	DN600 x 60° BMax Bend RRJ F&F	TBC
GR0245090	DN450 x 90° BMax Bend RRJ F&F	568
GR0252590	DN525 x 90° BMax Bend RRJ F&F	607
GR0260090	DN600 x 90° BMax Bend RRJ F&F	644

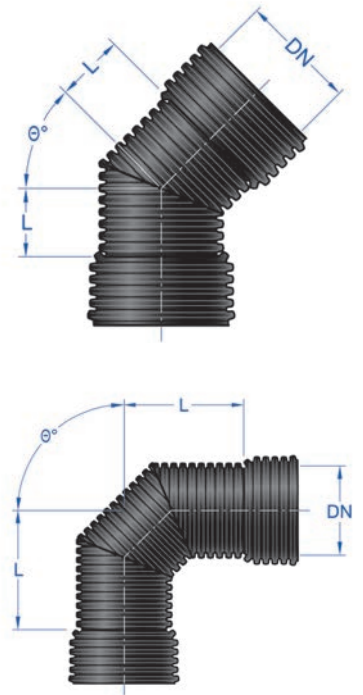

*Larger sizes are available on request

- Note:
- Other angles are available on request.
 - BlackMax Bends are subject to availability at time of ordering.
 - Dimensions are approximate only.
 - All images are indicative only and not to scale.

BlackMax Equal Junctions x 45° FFF RRJ – DN225 to DN375 (Fabricated with PVC-U DWV Pipe sections)

Product Code	Description	L (mm)	L1 (mm)	L2 (mm)
GWR2422545	DN225 x 45° BMax Equal Junction RRJ F&F	521	386	386
GWR2430045	DN300 x 45° BMax Equal Junction RRJ F&F	714	514	514
GWR2437545	DN375 x 45° BMax Equal Junction RRJ F&F	816	600	600

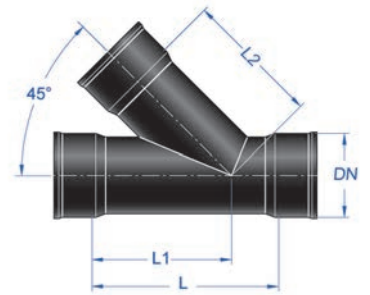

BlackMax Equal Junctions x 45° FFF RRJ – DN450 to DN600* (Fabricated with BlackMax PP Pipe sections)

Product Code	Description	L (mm)	L1 (mm)	L2 (mm)
GR2445045	DN450 x 45° BMax Equal Junction RRJ F&F	1042	748	748
GR2452545	DN525 x 45° BMax Equal Junction RRJ F&F	1158	838	838
GR2460045	DN600 x 45° BMax Equal Junction RRJ F&F	1356	956	956

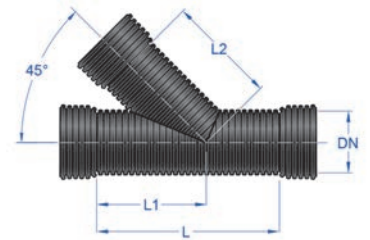

*Larger sizes are available on request

BlackMax Reducing Junctions x 45° FFF RRJ – DN225 to DN375 (Fabricated with PVC-U DWV Pipe sections)

Product Code	Description	L (mm)	L1 (mm)	L2 (mm)
GWR25221045	DN225 x dn100 (DWV RRJ) x 45° BMax Reducing Junction F&F	362	306	315
GWR25221545	DN225 x dn150 (DWV RRJ) x 45° BMax Reducing Junction F&F	393	321	324
GWR25301045	DN300 x dn100 (DWV RRJ) x 45° BMax Reducing Junction F&F	394	354	361
GWR25301545	DN300 x dn150 (DWV RRJ) x 45° BMax Reducing Junction F&F	365	390	378
GWR25371045	DN375 x dn100 (DWV RRJ) x 45° BMax Reducing Junction F&F	530	468	412
GWR25371545	DN375 x dn150 (DWV RRJ) x 45° BMax Reducing Junction F&F	530	463	451
GWR25302245	DN300 x dn225 x 45° BMax Reducing Junction F&F	640	483	481
GWR25372245	DN375 x dn225 x 45° BMax Reducing Junction F&F	630	527	531
GWR25373045	DN375 x dn300 x 45° BMax Reducing Junction F&F	730	573	590

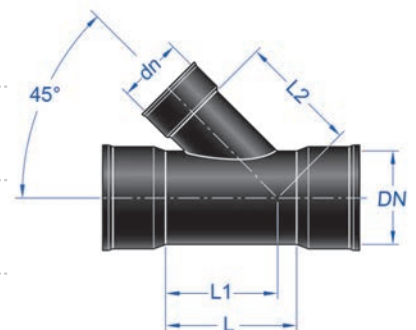
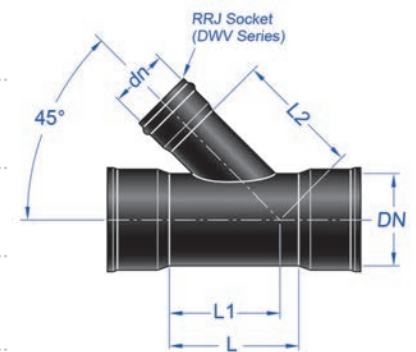

- Note:
- BlackMax Junctions are subject to availability at time of ordering.
 - For Junctions with a DWV SWJ Branch add 'S' at the end of the product code.
 - For Junctions with DN225 or DN300 DWV Branches add 'R' at the end of the product code.
 - Dimensions are approximate only.
 - All images are indicative only and not to scale.

BlackMax Reducing Junctions x 45° FFF RRJ – DN450 to DN600* (Fabricated with BlackMax PP Pipe Sections)

Product Code	Description	L (mm)	L1 (mm)	L2 (mm)
GR25452245	DN450 x dn225 x 45° BMax Reducing Junction F&F	725	590	604
GR25453045	DN450 x dn300 x 45° BMax Reducing Junction F&F	831	643	678
GR25453745	DN450 x dn375 x 45° BMax Reducing Junction F&F	925	684	700
GR25522245	DN525 x dn225 x 45° BMax Reducing Junction F&F	732	635	658
GR25523045	DN525 x dn300 x 45° BMax Reducing Junction F&F	838	688	732
GR25523745	DN525 x dn375 x 45° BMax Reducing Junction F&F	941	741	753
GR25524545	DN525 x dn450 x 45° BMax Reducing Junction F&F	1048	793	820
GR25602245	DN600 x dn225 x 45° BMax Reducing Junction F&F	735	686	725
GR25603045	DN600 x dn300 x 45° BMax Reducing Junction F&F	841	739	800
GR25603745	DN600 x dn375 x 45° BMax Reducing Junction F&F	953	791	820
GR25604545	DN600 x dn450 x 45° BMax Reducing Junction F&F	1048	834	887
GR25605245	DN600 x dn525 x 45° BMax Reducing Junction F&F	1422	1090	906

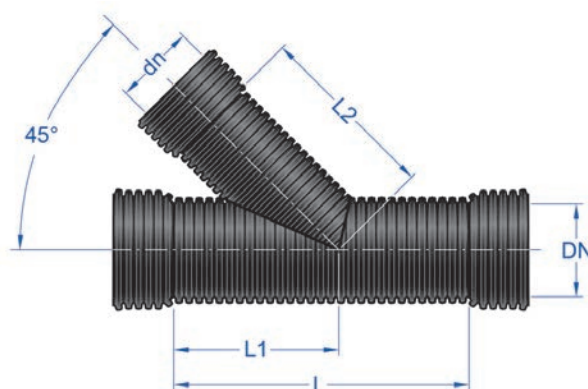

*Larger sizes are available on request

- Note:
- BlackMax Junctions are subject to availability at time of ordering.
 - Dimensions are approximate only.
 - All images are indicative only and not to scale.

BlackMax Reducing Junction x 45° FFF RRJ

Product Code	Description	L (mm)	L1 (mm)	L2 (mm)
GR25451045	DN450 x dn100 ¹ (110mm OD spigot) x 45° BMax Reducing Junction	555	505	525
GR25451545	DN450 x dn150 ¹ (160mm OD spigot) x 45° BMax Reducing Junction	626	540	600
GR25521045	DN525 x dn100 ¹ (110mm OD spigot) x 45° BMax Reducing Junction	555	543	630
GR25521545	DN525 x dn150 ¹ (160mm OD spigot) x 45° BMax Reducing Junction	626	580	655
GR25601045	DN600 x dn100 ¹ (110mm OD spigot) x 45° BMax Reducing Junction	615	600	700
GR25601545	DN600 x dn150 ¹ (160mm OD spigot) x 45° BMax Reducing Junction	686	636	725

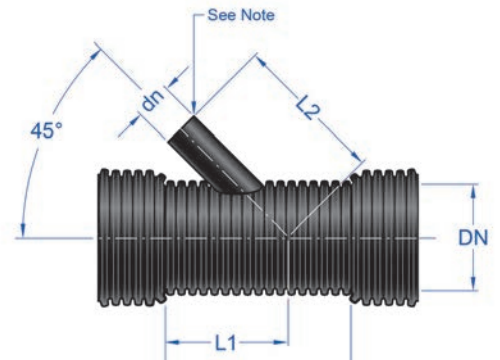

Note: For dn100 or dn150 DWV RRJ branches use a PVC DWV RRJ coupling or Fernco Coupling for connection with DWV PVC pipes. (Note: Couplings are not included with the Junctions)

BlackMax Equal Tees FFF RRJ – DN225 to DN375 (Fabricated with PVC-U DWV Pipe sections)

Product Code	Description	L (mm)	L1 (mm)
GWR2422590	DN225 x 90° BMax Equal Tee RRJ F&F	416	208
GWR2430090	DN300 x 90° BMax Equal Tee RRJ F&F	564	282
GWR2437590	DN375 x 90° BMax Equal Tee RRJ F&F	660	330

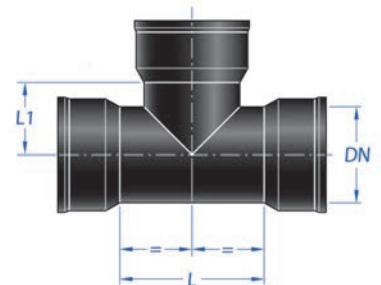

BlackMax Equal Tees FFF RRJ – DN450 to DN600* (Fabricated with BlackMax PP Pipe Sections)

Product Code	Description	L (mm)	L1 (mm)
GR2445090	DN450 x 90° BMax Equal Tee RRJ F&F	810	405
GR2452590	DN525 x 90° BMax Equal Tee RRJ F&F	930	465
GR2460090	DN600 x 90° BMax Equal Tee RRJ F&F	1008	504

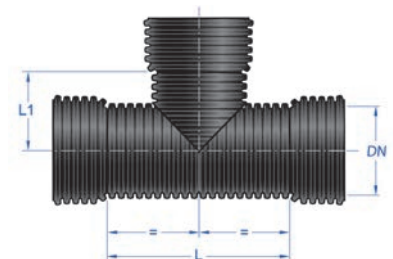

*Larger sizes are available on request

Note:

- BlackMax Reducing Junctions are subject to availability at time of ordering.
- Dimensions are approximate only.
- All images are indicative only and not to scale.

BlackMax Reducing Tees FFF RRJ – DN225 to DN375 (Fabricated with PVC-U DWV Pipe sections)

Product Code	Description	L (mm)	L1 (mm)
GWR25221090	DN225 x dn100 x 90° BMax Reducing Tee RRJ F&F	265	189
GWR25221590	DN225 x dn150 x 90° BMax Reducing Tee RRJ F&F	163	193
GWR25301090	DN300 x dn100 x 90° BMax Reducing Tee RRJ F&F	174	241
GWR25301590	DN300 x dn150 x 90° BMax Reducing Tee RRJ F&F	199	245
GWR25371090	DN375 x dn100 x 90° BMax Reducing Tee RRJ F&F	265	274
GWR25371590	DN375 x dn150 x 90° BMax Reducing Tee RRJ F&F	265	288

Note: For DN100 & DN150 DWV SWJ branch add 'S' at the end of the product code.

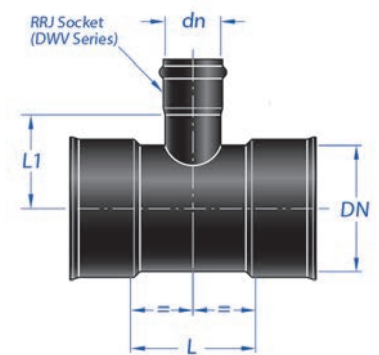

BlackMax Reducing Tees FFF RRJ

Product Code	Description	L (mm)	L1 (mm)
GWR25302290	DN300 x dn225 x 90° BMax Reducing Tee RRJ F&F	244	261
GWR25372290	DN375 x dn225 x 90° BMax Reducing Tee RRJ F&F	265	323
GWR25373090	DN375 x dn300 x 90° BMax Reducing Tee RRJ F&F	464	442

Note: For PVC DWV SWJ branch add 'S' at the end of the product code.
For PVC DWV RRJ branch add 'R' at the end of the product code.

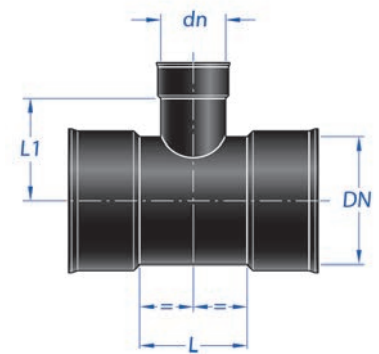

- Note:
- Dimensions are approximate only.
 - BlackMax Tees are subject to availability at time of ordering.
 - All images are indicative only and not to scale.



BlackMax Reducing Junctions x 45° FFF RRJ – DN450 to DN600* (Fabricated with BlackMax PP Pipe Sections)

Product Code	Description	L (mm)	L1 (mm)
GR25452290	DN450 x dn225 x 90° BMax Reducing Tee RRJ F&F	630	427
GR25453090	DN450 x dn300 x 90° BMax Reducing Tee RRJ F&F	704	427
GR25453790	DN450 x dn375 x 90° BMax Reducing Tee RRJ F&F	778	427
GR25522290	DN525 x dn225 x 90° BMax Reducing Tee RRJ F&F	630	465
GR25523090	DN525 x dn300 x 90° BMax Reducing Tee RRJ F&F	650	465
GR25523790	DN525 x dn375 x 90° BMax Reducing Tee RRJ F&F	778	465
GR25524590	DN525 x dn450 x 90° BMax Reducing Tee RRJ F&F	854	465
GR25602290	DN600 x dn225 x 90° BMax Reducing Tee RRJ F&F	624	514
GR25603090	DN600 x dn300 x 90° BMax Reducing Tee RRJ F&F	720	514
GR25603790	DN600 x dn375 x 90° BMax Reducing Tee RRJ F&F	780	514
GR25604590	DN600 x dn450 x 90° BMax Reducing Tee RRJ F&F	856	514
GR25605290	DN600 x dn525 x 90° BMax Reducing Tee RRJ F&F	932	514

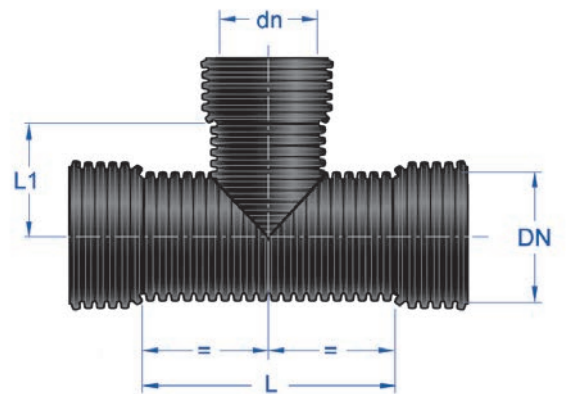

*Larger sizes are available on request

- Note:
- BlackMax Reducing Tees are subject to availability at time of ordering.
 - Dimensions are approximate only.
 - All images are indicative only and not to scale.

BlackMax Couplings FF RRJ – DN225 to DN375 (Fabricated with PVC-U DWV Pipe sections)

Product Code	Description	L (mm)
GWR57225	DN225 BMax Coupling F&F	116
GWR57300	DN300 BMax Coupling F&F	148
GWR57375	DN300 BMax Coupling F&F	149

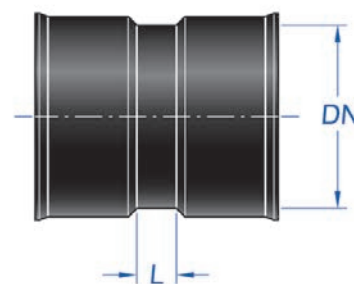

BlackMax Couplings FF RRJ – DN450 to DN600* (Fabricated with BlackMax PP Pipe Sections)

Product Code	Description	L (mm)
GR57450	DN450 BMax Coupling F&F	400
GR57525	DN525 BMax Coupling F&F	400
GR57600	DN600 BMax Coupling F&F	400

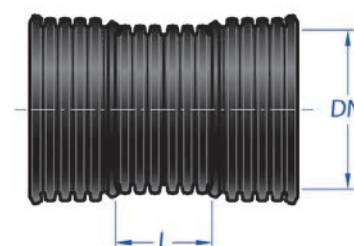

*Larger sizes are available on request

BlackMax End Caps RRJ – DN225 to DN375 (Fabricated with PVC-U DWV Pipe sections)

Product Code	Description	L (mm)
GWR105225	DN225 BMax CAP RRJ	145
GWR105300	DN300 BMax CAP RRJ	150
GWR105375	DN375 BMax CAP RRJ	185

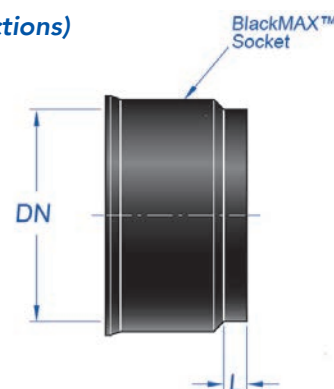

BlackMax End Caps RRJ – DN450 to DN600* (Fabricated with BlackMax PP Pipe Sections)

Product Code	Description	t (mm)	L (mm)
GR105450	DN450 BMax CAP RRJ	15	200
GR105525	DN525 BMax CAP RRJ	20	230
GR105600	DN600 BMax CAP RRJ	20	270

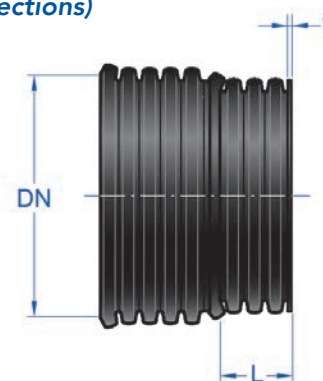

*Larger sizes are available on request

- Note:
- BlackMax Couplings and Caps are subject to availability at time of ordering.
 - Dimensions are approximate only.
 - All images are indicative only and not to scale.

BlackMax Plugs RRJ – DN225 to DN600* (Fabricated with BlackMax PP Pipe Sections)

Product Code	Description	L (mm)
GR106225	DN225 BMax Plug	160
GR106300	DN300 BMax Plug	180
GR106375	DN375 BMax Plug	215
GR106450	DN450 BMax Plug	270
GR106525	DN525 BMax Plug	310
GR106600	DN600 BMax Plug	360

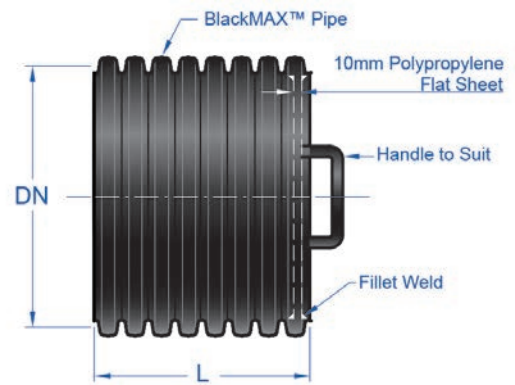

*Larger sizes are available on request

BlackMax Level Invert Tapers FF RRJ – DN225 to DN375 (Fabricated with PVC-U DWV Pipe sections)

Product Code	Description	L (mm)	L1 (mm)
GWR722215	DN225 x dn150 BMax Level Invert Taper Socket x DWV RRJ F&F	460	41
GWR723015	DN300 x dn150 BMax Level Invert Taper Socket x DWV RRJ F&F	108	69
GWR723022	DN300 x dn225 BMax Level Invert Taper F&F	234	33
GWR723715	DN375 x dn150 BMax Level Invert Taper Socket x DWV RRJ F&F	168	110
GWR723722	DN375 x dn225 BMax Level Invert Taper F&F	203	65
GWR723730	DN375 x dn300 BMax Level Invert Taper F&F	405	43

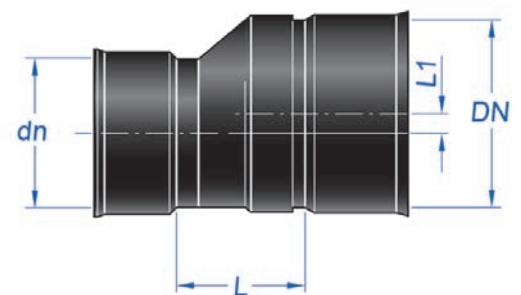

- Note:
- BlackMax Plugs and Reducers are subject to availability at time of ordering.
 - For Tapers with a reducing dn225 and dn300 DWV SWJ Socket add 'S' at the end of the product code.
 - For Tapers with a reducing dn225 or dn300 DWV RRJ Socket add 'R' at the end of the product code.
 - Dimensions are approximate only.
 - All images are indicative only and not to scale.

BlackMax Level Invert Tapers FF RRJ – DN450 to DN600* (Fabricated with BlackMax PP Pipe Sections)

Product Code	Description	L (mm)
GR724522	DN450 x dn225 BMax Taper F&F	400
GR724530	DN450 x dn300 BMax Taper F&F	400
GR724537	DN450 x dn375 BMax Taper F&F	400
GR725222	DN525 x dn225 BMax Taper F&F	400
GR725230	DN525 x dn300 BMax Taper F&F	400
GR725237	DN525 x dn375 BMax Taper F&F	400
GR725245	DN525 x dn450 BMax Taper F&F	400
GR726022	DN600 x dn225 BMax Taper F&F	400
GR726030	DN600 x dn300 BMax Taper F&F	400
GR726037	DN600 x dn375 BMax Taper F&F	400
GR726045	DN600 x dn450 BMax Taper F&F	400
GR726045	DN600 x dn525 BMax Taper F&F	400

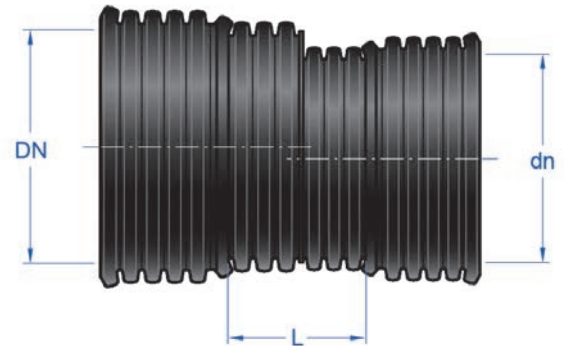

*Larger sizes are available on request

BlackMax Adaptor FF BMax x DWV RRJ – DN225 to DN375 (Fabricated with PVC-U DWV Pipe sections)

Product Code	Description	L (mm)
GWR612222	DN225 BMax Adaptor - BMax x DWV RRJ F&F	77
GWR613030	DN300 BMax Adaptor - BMax x DWV RRJ F&F	155
GWR613737	DN375 BMax Adaptor - BMax x DWV RRJ F&F	107

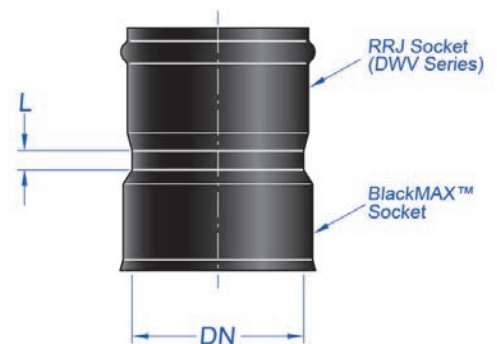

BlackMax Adaptor FF BMax RRJ x DWV SWJ – DN225 to DN375 (Fabricated with PVC-U DWV Pipe sections)

Product Code	Description	L (mm)
GWR622222	DN225 BMax Adaptor - BMax x DWV SWJ F&F	65
GWR623030	DN300 BMax Adaptor - BMax x DWV SWJ F&F	140
GWR623737	DN375 BMax Adaptor - BMax x DWV SWJ F&F	95

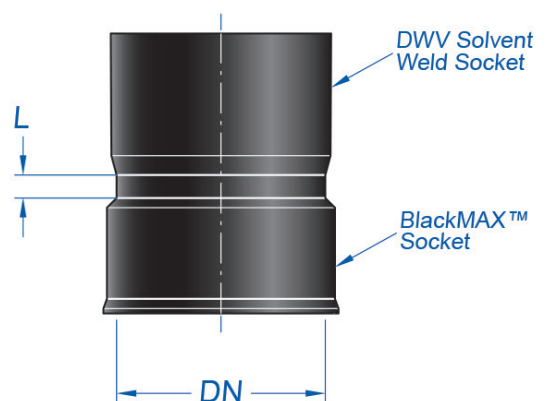

Note:

- BlackMax Tapers and Adaptors are subject to availability at time of ordering.
- Dimensions are approximate only.
- All images are indicative only and not to scale.

BlackMax Adaptor MF BMax RRJ x DWV SP – DN225 to DN375 (Fabricated with PVC-U DWV Pipe sections)

Product Code	Description	L (mm)	L1 (mm)
GWR602222	DN225 BMax Adaptor - BMax x DWV SP F&M	375	145
GWR603030	DN300 BMax Adaptor - BMax x DWV SP F&M	470	150
GWR603737	DN375 BMax Adaptor - BMax x DWV SP F&M	450	185

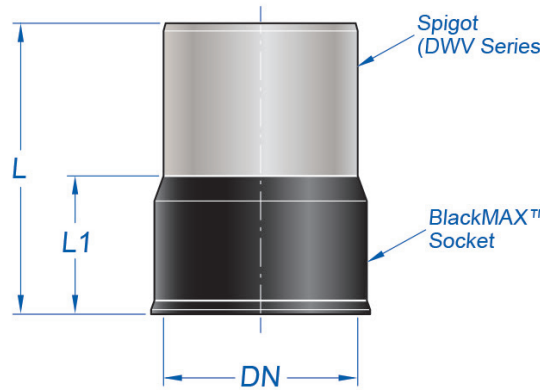

- Note:
- BlackMax Adaptors are subject to availability at time of ordering.
 - Dimensions are approximate only.
 - All images are indicative only and not to scale.



2.4.3 SADDLES

BlackMax Stormwater Saddle x DWV RRJ (Fabricated with PVC-U DWV Pipe sections)

Product Code	Description	L (mm)	L1 (mm)
GWR50221090	DN225 x dn100 BMax Stormwater saddle DWV RRJ	260	80
GWR50221590	DN225 x dn150 BMax Stormwater saddle DWV RRJ	260	120
GWR50301090	DN300 x dn100 BMax Stormwater saddle DWV RRJ	280	80
GWR50301590	DN300 x dn150 BMax Stormwater saddle DWV RRJ	280	120
GWR50371090	DN375 x dn100 BMax Stormwater saddle DWV RRJ	320	80
GWR50371590	DN375 x dn150 BMax Stormwater saddle DWV RRJ	320	120
GWR50372290	DN375 x dn225 BMax Stormwater saddle DWV RRJ	320	160
GWR50451090	DN450 x dn100 BMax Stormwater saddle DWV RRJ	380	80
GWR50451590	DN450 x dn150 BMax Stormwater saddle DWV RRJ	380	120
GWR50452290	DN450 x dn225 BMax Stormwater saddle DWV RRJ	380	160
GWR50521090	DN525 x dn100 BMax Stormwater saddle DWV RRJ	390	80
GWR50521590	DN525 x dn150 BMax Stormwater saddle DWV RRJ	390	120
GWR50601090	DN600 x dn100 BMax Stormwater saddle DWV RRJ	410	80
GWR50601590	DN600 x dn150 BMax Stormwater saddle DWV RRJ	410	120

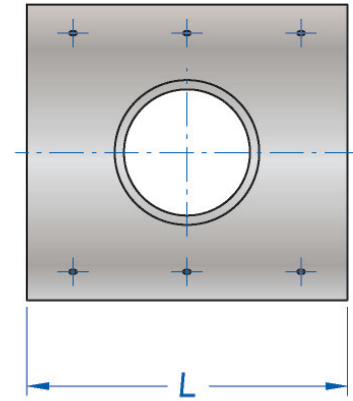

Plan View

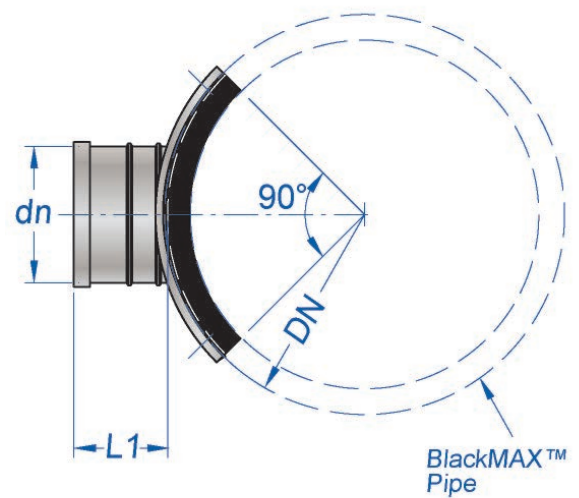

Side Elevation

- Note:
- BlackMax Stormwater Saddles are subject to availability at time of ordering.
 - Standard branches are supplied as DWV RRJ. SWJ joints are also available on request only. Add an 'S' at the end of the Product Code when specifying this type of joint.
 - Dimensions are approximate only.
 - All images are indicative only and not to scale.

2.4.4 FERNCO® SADDLES

The Fernco™ Saddle is a watertight stormwater saddle for incoming lateral connections with BlackMax pipes.

Fernco™ Saddles are designed to resist infiltration, exfiltration, and root intrusion between the BlackMax™ pipe and the Saddle.

The PA Fernco Saddle includes a RRJ branch off take with an encapsulated rubber ring seal, for direct connection with

smooth wall PVC DWV or PE (SDR26) pipes. Reducers or Adaptors are also available for non-direct connections with smaller pipe sizes or other pipe materials.

The UA Fernco Saddle includes a Spigot branch off take for connection with lateral pipes. Couplings, Reducers and Adaptors are available for connection with smaller pipe sizes or other pipe materials.

PA Saddle

For Plastic Pipes



PA SADDLE

BlackMax pipe sizes DN300 to DN600

Materials EPDM, ABS plastic, Glass-Filled Nylon, 316 Stainless Steel

Direct lateral pipe deflection < 8.5°

Branch RRJ @ 90° for DN150 PVC DWV SN8 smooth wall pipe (160mm OD) or 160mm OD smooth wall SDR26 PE pipe

Pressure Maximum 50kPa

Vacuum -30kPa

Standards BS EN 681-1, BS EN295-3, BS EN 13259, WIS 4-35-01 WRc Approved

UA Saddle

For Plastic Pipes DN700 and above

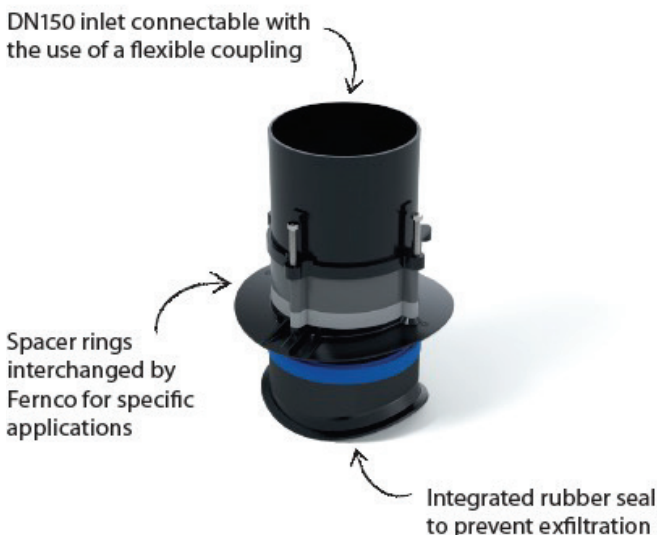

UA SADDLE

BlackMax pipe sizes DN750 to DN1200

Materials EPDM, ABS plastic, Glass-Filled Nylon, 316 Stainless Steel

Lateral pipe deflection < 5°

Branch Spigot at 90° for DN150 PVC DWV SN8 smooth wall pipe (160mm OD) or 160mm OD smooth wall SDR26 PE pipe with approved coupling

Pressure Maximum 50kPa

Vacuum -30kPa

Standards BS EN 681-1, BS EN295-3, BS EN 13259, WIS 4-35-01 WRc Approved

Fernco Saddles - DN300 to DN1200

Product Code	Description	Type	Fernco Reference	Weight (kg)	Width (mm)	Height (cm)
GWR54301590	DN300 x dn150 BlkMax Saddle	Saddle	PA1530 ABS	1.56	30	30
GWR54371590	DN375 x dn150 BlkMax Saddle	Saddle	PA1530M ABS	1.56	30	30
GWR54451590	DN450 x dn150 BlkMax Saddle	Saddle	PA1540M ABS	1.56	30	30
GWR54521590	DN525 x dn150 BlkMax Saddle	Saddle	PA1560 ABS	1.60	30	30
GWR54601590	DN600 x dn150 BlkMax Saddle	Saddle	PA1560 ABS	1.60	30	30
GWR54751590	DN750 x dn150 BlkMax Saddle	Saddle	UA04 ABS	1.79	25	34.2
GWR54901590	DN900 x dn150 BlkMax Saddle	Saddle	UA06 ABS	1.79	25	34.2
GWR541001590	DN1000 x dn150 BlkMax Saddle	Saddle	UA04 ABS	1.79	25	34.2
GWR541201590	DN1200 x dn150 BlkMax Saddle	Saddle	UA10 ABS	1.79	25	34.2
GWR54177HSAW	DN150 Fernco Hole Saw kit 177mm OD	Hole Saw	FHSK77-150	7.00	17.7	17.7
GWR54AKEY	Fernco Allen key (T-TAK)	Allen Key	T Ball FTLS03	0.50	3	3

2.4.5 BLACKMAX STAINLESS STEEL CLAMPS

BlackMax Stainless Steel Repair Clamp – DN225 to DN600 (For minor repairs)

Product Code	Description	L (mm)
C37018.22530	DN225 BMax Repair Clamp (3 bolts)	300
C37018.30030	DN300 BMax Repair Clamp (3 bolts)	300
C37018.37530	DN375 BMax Repair Clamp (3 bolts)	300
C37018.45040	DN450 BMax Repair Clamp (5 bolts)	400
C37018.52540	DN525 BMax Repair Clamp (5 bolts)	400
C37018.60040	DN600 BMax Repair Clamp (5 bolts)	400

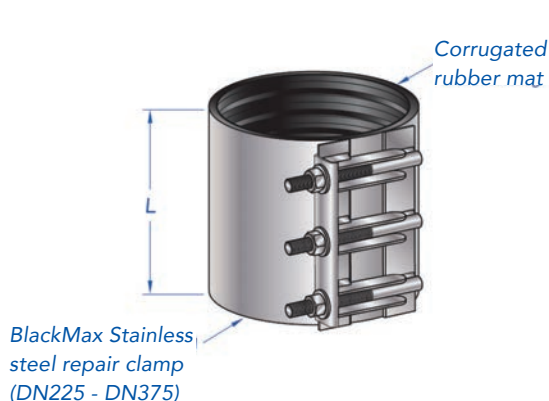

- Note:
- BlackMax SS clamps are subject to availability at time of ordering
 - Installation instructions must be strictly followed. Refer to the markings on the clamp, attached label and section 4.12.1 Minor Repairs of this guide for further details
 - The clamps must not be changed, altered or modified
 - Dimensions are approximate only
 - All images are indicative only and not to scale

BlackMax Stainless Steel Joiner Clamp – DN225 to DN600 (For major repairs)

Product Code	Description	L (mm)
C37019.22520	DN225 BMax Joiner Clamp (2 bolts) incl. rubber sleeve and 2x BlackMax rings	200
C37019.30020	DN300 BMax Joiner Clamp (2 bolts) incl. rubber sleeve and 2x BlackMax rings	200
C37019.37520	DN375 BMax Joiner Clamp (2 bolts) incl. rubber sleeve and 2x BlackMax rings	200
C37019.45030	DN450 BMax Joiner Clamp (3 bolts) incl. rubber sleeve and 2x BlackMax rings	300
C37019.52530	DN525 BMax Joiner Clamp (3 bolts) incl. rubber sleeve and 2x BlackMax rings	300
C37019.60030	DN600 BMax Joiner Clamp (3 bolts) incl. rubber sleeve and 2x BlackMax rings	300

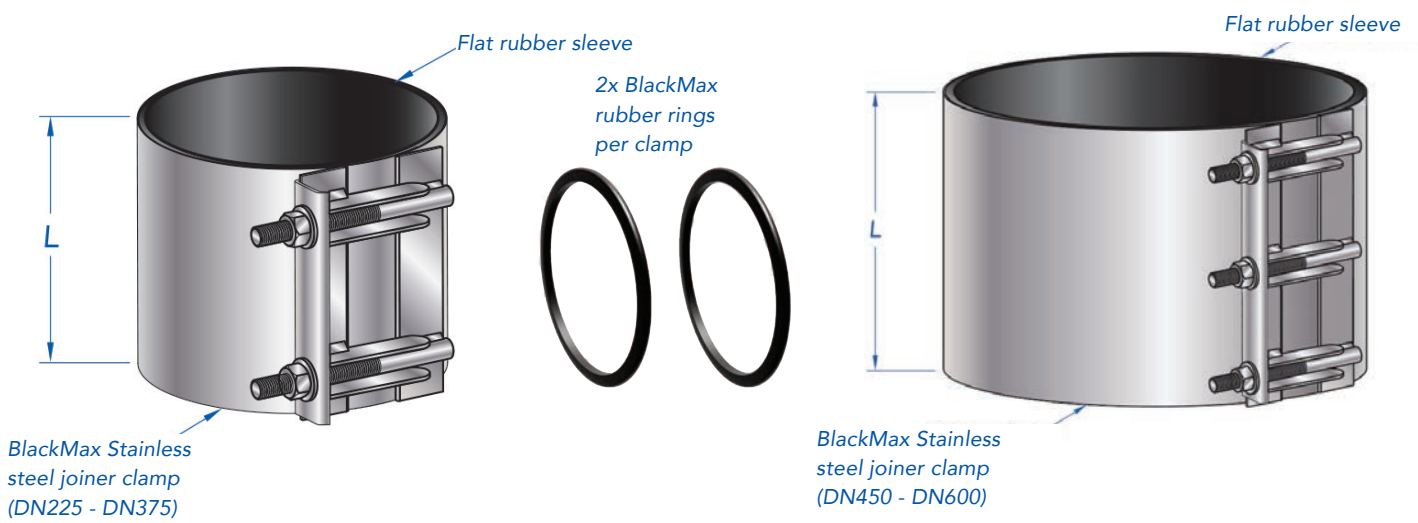

- Note:
- BlackMax SS Clamps are subject to availability at time of ordering.
 - Each BlackMax SS Joiner Clamp is supplied with 2 BlackMax rubber rings.
 - Installation instructions must be strictly followed. Refer to the markings on the clamp, attached label and section 4.12.2 Major Repairs of this guide for further details.
 - The clamps must not be changed, altered or modified.
 - Dimensions are approximate only.
 - All images are indicative only and not to scale.

2.4.6 FERNCO® SHEAR BANDED COUPLINGS (BLACKMAX DN225 TO DN1200)

Fernco Shear Banded Couplings are used to provide a secure and reliable connection between two BlackMax pipes.

When connecting two plain-ended BlackMax pipes with these couplings, it's important to ensure that the BlackMax rubber ring seals are properly seated within the pipe valley and the couplings assembled and installed correctly to maintain the integrity of the joint and prevent leaks.

The recommended procedures outlined in Section 4.12.3 are essential to ensure that repairs are carried out effectively and that the piping system continues to function as intended.

The followings outlines the range of sizes available from Iplex.

NOTE: EACH FERNCO SHEAR BANDED COUPLING MUST BE INSTALLED WITH 2 BLACKMAX RUBBER RING SEALS TO SEAL THE COUPLING WITH THE PIPE. SEE SECTION 4.12.3 FURTHER INFORMATION

Product Code	Description	Type	Fernco Reference	Width (mm)	BlackMax OD (mm)
C892.250275	DN225 BlackMax Standard Coupling	Standard	SC275A	190	259
C892.344	DN300 BlackMax Extra Wide Standard Coupling	Extra Wide Standard	SC360WA	300	344
C892.428	DN375 BlackMax Extra Wide Standard	Extra Wide Standard	SC445WA	300	428
C892.514	DN450 BlackMax Extra Wide Standard Coupling	Extra Wide Standard	SC525WA	300	514
C892.600	DN525 BlackMax Extra Wide Standard Coupling	Extra Wide Standard	SC620WA	300	600
C892.682	DN600 BlackMax Extra Wide Large Coupling	Extra Wide large	LC600WA	300	682
C892.843	DN750 BlackMax Extra Wide Large Coupling	Extra Wide large	LC800WA	300	843
C892.1010	DN900 BlackMax Extra Wide Large Coupling	Extra Wide large	LC1000WA	300	1010
C892.1103	DN1000 BlackMax Extra Wide large Coupling	Extra Wide large Coupling	LC1103WA	300	1103
C892.1342	DN1200 BlackMax Magnum Coupling	Magnum	MAG1348	345	1348

- Note:
- Materials - EPDM Rubber, Stainless Steel 304
 - Standard – AS/NZS 4327
 - WaterMARK Certified
 - WSAA Appraised

Fernco Standard Coupling (DN225)



Fernco Extra Wide Standard Coupling (DN300 to DN525)



Fernco Extra Wide Large Coupling (DN600 to DN1000)



Fernco Magnum Coupling (DN1200)



All images are indicative only and not to scale.

2.5 PIPE JOINTING

BlackMax pipes and fittings are manufactured with a spigot and socket rubber ring jointing system.

A profiled rubber ring is assembled in the second trough from the spigot end and is compressed as the spigot enters the socket. This jointing system can be used after cutting the pipe in the field for short length adjustments. Joined pipes may be deflected by up to 2 degrees for sizes DN225 to DN750 and up to 1 degree for sizes DN900 to DN1200 from the socket off-line after assembly. See Section 4.7.2 for details of the jointing procedure.

2.5.1 JOINT CROSS SECTION DETAILS

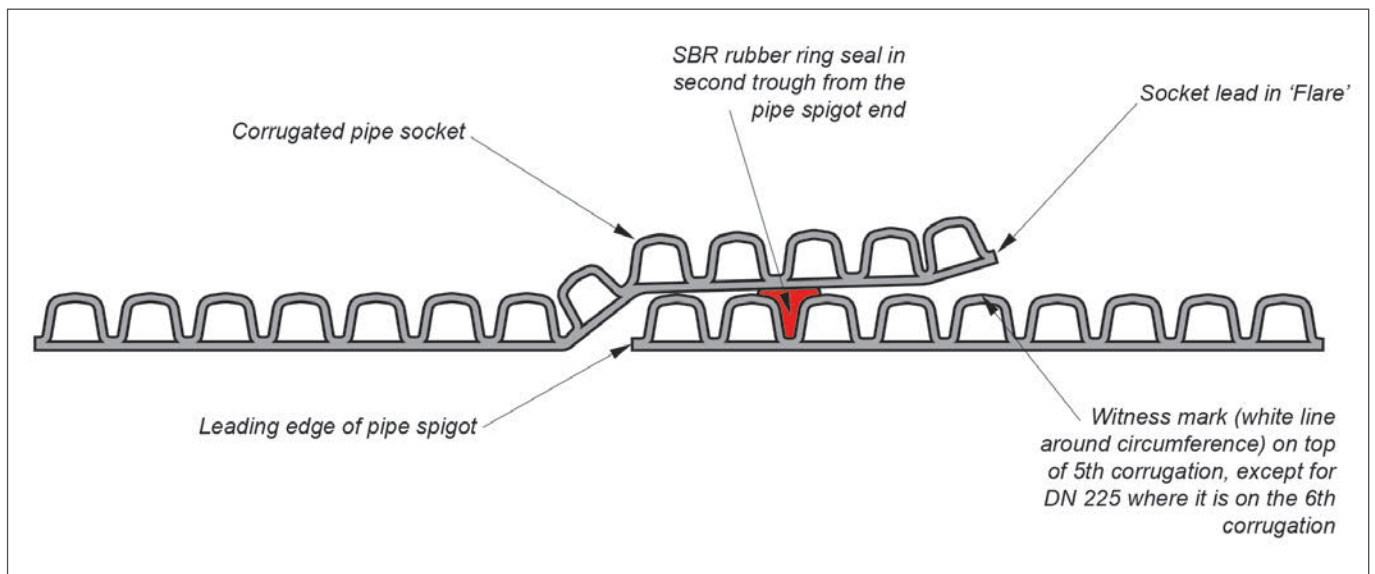

DN225 to DN525 spigot and socket rubber ring cross section assembly

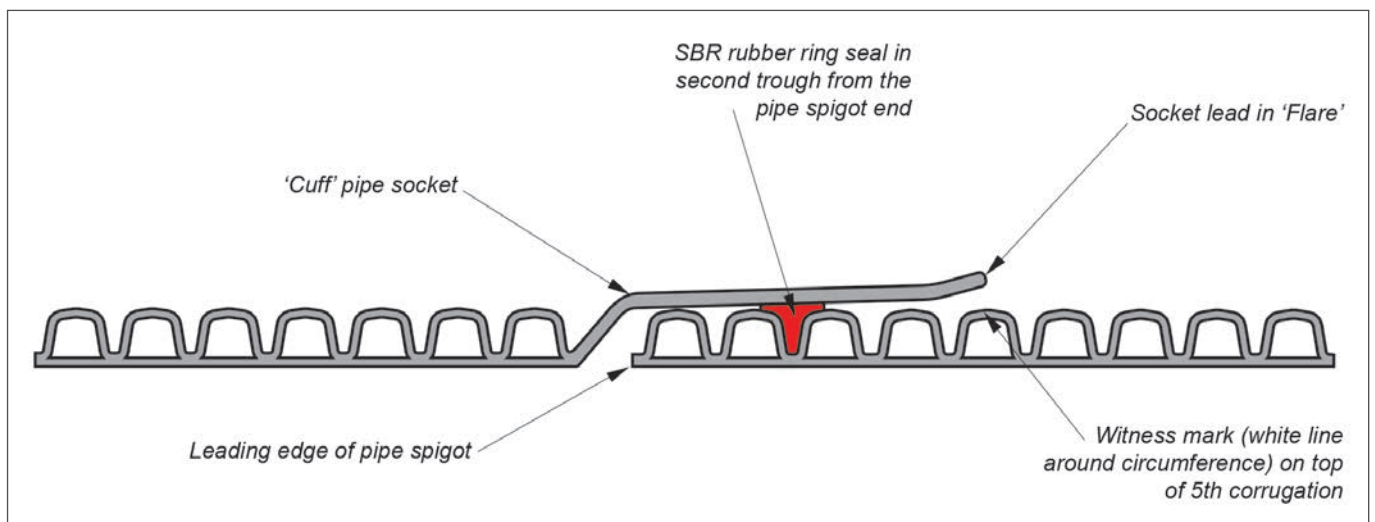

DN600 to DN1200 spigot and socket rubber ring cross section assembly

All images are indicative only and not to scale.

2.5.2 RUBBER RING JOINT DESIGN AND PERFORMANCE

Poor joint performance can lead to leakage and tree root intrusion causing pipe blockages and ground water infiltration. Infiltration through the pipe joint can also cause silting of the pipeline and long-term maintenance issues. For this reason, the quality of the joint is critical to the performance of any pipe system.

The BlackMax elastomeric seal provides a high degree of resistance to infiltration, exfiltration, and root ingress. The SBR rubber ring seal is compliant to 'AS1646 Elastomeric seals for water works purposes' and is resistant to chemical and microbiological attack.

Cross section of the corrugated reinforced BlackMax RRJ pipe joint (DN225 to DN525)

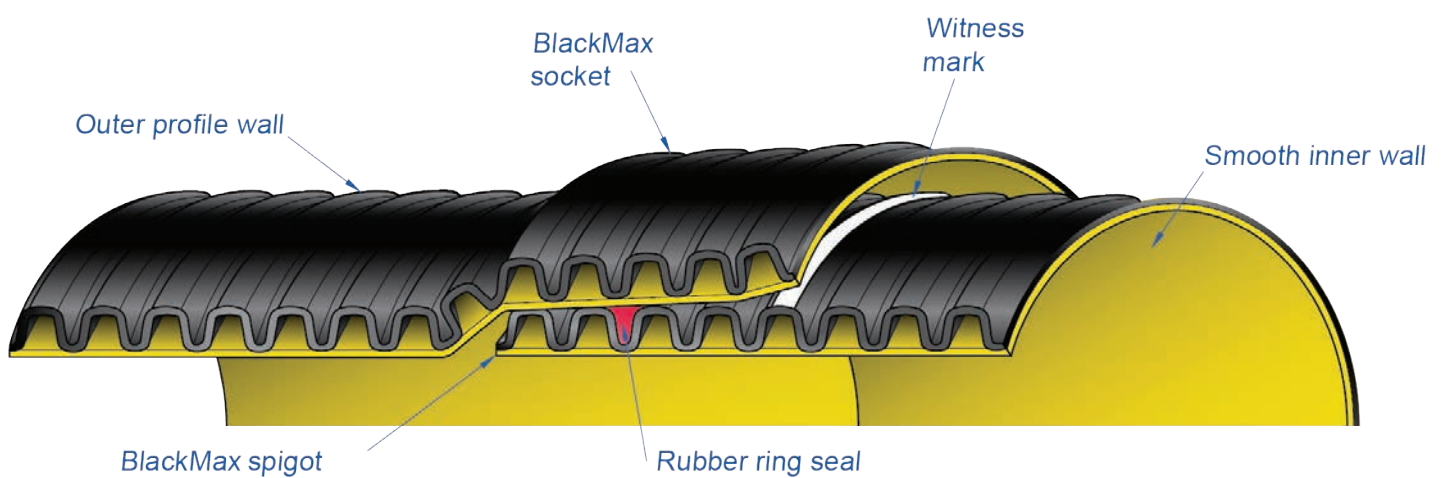

Cross section of the double wall Patented BlackMax RRJ pipe joint (DN600 to DN1200)

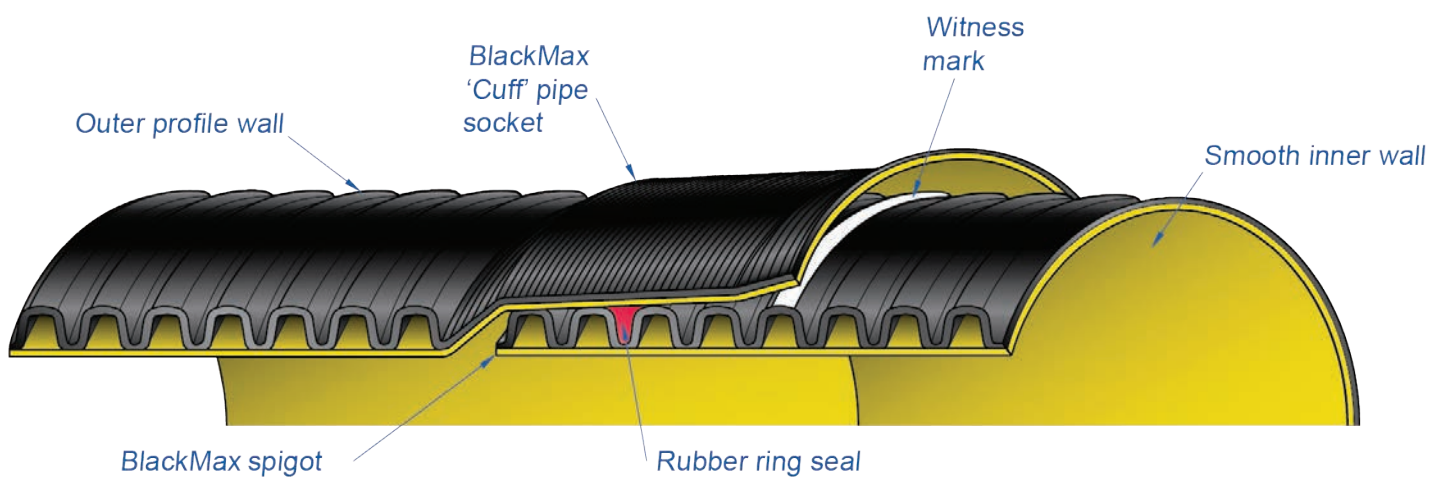

All images are indicative only and not to scale.

2.5.3 JOINT TIGHTNESS TESTS

The BlackMax pipe joint has been tested in accordance with the performance requirements in 'AS/NZS 5065 Polyethylene and polypropylene pipes and fittings for drainage and sewerage applications. Section 3.4.3 (AS/NZS 5065) 'Contact width and pressure' specifies a minimum contact pressure of 0.4MPa between the rubber ring seal and the pipe socket wall over a distance of at least 4mm. These conditions have been shown to provide high resistance to tree root intrusion for plastic pipes.

2.5.4 PRESSURE AND VACUUM

The BlackMax pipe joint has been tested in accordance with the performance requirements in 'AS/NZS 5065 Polyethylene and polypropylene pipes and fittings for drainage and sewerage applications'. Sections 3.4.1 (AS/NZS 5065) 'Hydrostatic pressure test' and 3.4.2 'Liquid infiltration test' specifies a pressure test of 80 +5, -0 kPa for 60 +5, -0 min and a vacuum test of -80 +5, -0 kPa for 60 +5, -0 min with a diametral distortion of 7.5%.

2.6 PIPE STIFFNESS

The ring stiffness of a flexible pipe indicates its ability to resist soil loads, external hydrostatic pressure, negative internal pressures, traffic, and construction loads. The nominal ring stiffness can be determined by laboratory testing and is expressed in N/m/m - Reference AS/NZS 2566.1 and AS/NZS 1462.22.

Pipe Description	Pipe Stiffness	Classification (AS/NZS 5065)
BlackMax	>8000 N/m/m	SN8

The high ring stiffness of BlackMax provides a high factor of safety for shallow and deep installations.

The stiffness criterion has been adopted by Australian Standard AS/NZS 2566.1 'Buried flexible pipelines - Part 1 Structural design' as being the most appropriate means of classifying flexible pipes manufactured from all types of plastics and metallic materials. It is defined as the force required to achieve the nominated deflection (typically 3% to 5%) on a specific length of pipe and is expressed mathematically as follows:

Equation 2.1

$$SN = \frac{Ff}{L.dv} \quad N/m/m$$

Equation 2.2

$$SN = \frac{EI}{D_m^3 \cdot 10^6} \quad N/m/m$$

SN = nominal stiffness (N/m/m)

E = apparent pipe material modulus (MPa)

F = force (N)

I = second moment of area (m⁴/m)

L = Length of test specimen (m)

dv = deflection (Diametral deformation) (m)

D_m = pipe diameter at neutral axis of the pipe wall (m)

f = the ovality correction factor, that is f = 10⁻⁵ (1860 + 2500 dv/D)

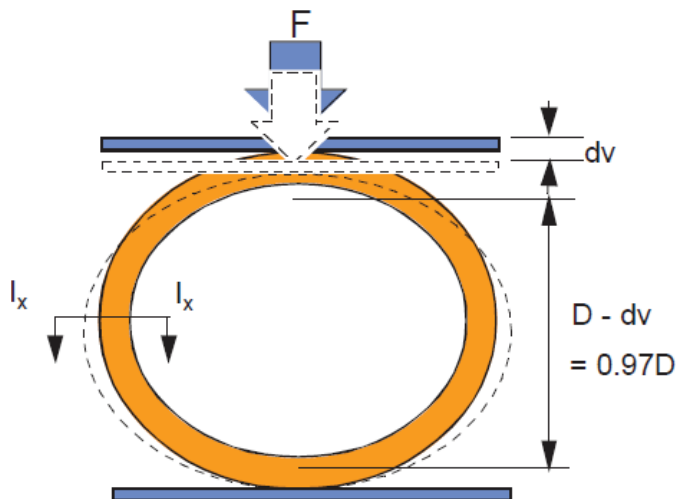

2.7 RING FLEXIBILITY

Ring flexibility demonstrates that BlackMax is not strain limited i.e., AS/NZS 1462.23 Ring flexibility test requires that pipes must withstand 30% deflection without cracking, rupture or buckling. This effectively represents a factor of safety of at least 4 in the case of a vertical deflection limit of 7.5%.

3.0 DESIGN

3.1 HYDRAULIC PERFORMANCE

BlackMax pipes fall into the smooth polymer pipe category of AS2200 ‘Design charts for water supply and sewerage’ and provide good hydraulic performance. Hydraulic performance may be affected by various adverse service factors including:

- Siltation or settlement of suspended particulate matter
- Roughening due to carrying of abrasive solids
- Joint imperfections or gaps
- Fitting types and configurations
- Pits and maintenance holes
- Gross pollutant traps

The notations used for equations in this section are as follows:

Notation	Description	SI unit
d	Internal diameter	m
f	Darcy friction coefficient	
g	Acceleration due to gravity	m/s ²
k	Equivalent hydraulic roughness	m
L	Length of pipeline	m
n	Manning n	
Q	Flow or Discharge	L/s
Q_p	Most probable peak dry weather flow	L/s
Q_f	Flow or Discharge – pipe flowing full	L/s
R	Hydraulic mean radius. i.e. flow area perimeter	m
R_e	Reynolds number	
R_p	Hydraulic mean radius for part full pipe	m
R_f	Hydraulic mean radius for full pipe i.e. D/4	m
S	Hydraulic gradient or slope of gravity flow sewer	m/m
V	Mean velocity	m/s
V_p	Mean velocity in part full pipe	m/s
V_f	Mean velocity in pipe flowing full	m/s
H_L	Friction head loss	m
y	Depth of flow above pipe invert	m
ρ	Fluid density	kg/m ³
ν	Kinematic viscosity	m ² /s
2θ	Angle (radians) subtended at pipe centre by water surface in invert – (Figure 3.5)	
T	Average boundary shear stress	Pa

To assist the designer in selecting the appropriate pipe diameter, flow resistance charts for BlackMax pipes have been provided. Figures 3.1, 3.2 and 3.3.

These charts relate friction loss to discharge and velocity with pipes running full and have been calculated using the Colebrook-White transition equation (Equation 3.1). The two values of roughness are generally accepted for the given applications.

Equation 3.1

$$v = -2(2gdS)^{0.5} \log \left(\frac{k}{3.7d} + \frac{2.51v}{D(2gdS)^{0.5}} \right) \frac{m}{s}$$

The Colebrook White equation considers the variation of viscosity with temperature and pipe roughness and is recognised as being one of the most accurate in general use. It requires iterative solutions and it is sometimes more convenient to use the Darcy head loss expression, with the Darcy friction co-efficient 'f' developed by P. Swamee and A. Jain based on the Colebrook-White approach. The Swamee-Jain equation approximates the Colebrook equation used to solve for the Darcy friction factor.

Equation 3.2

$$H_L = f \cdot \frac{L}{d} \cdot \frac{V^2}{2g} \quad m$$

Equation 3.3

$$f = \frac{0.25}{\left[\log \left(\frac{k}{3.7d} + \frac{5.74}{Re^{0.9}} \right) \right]^2}$$

The following flow resistance charts have been prepared based on the following assumptions:

- Temperature = 20°C
- Kinematic viscosity of water $\nu = 1.01 \times 10^{-6} \text{ m}^2/\text{s}$
- Equivalent hydraulic roughness $k = 0.01\text{mm}$ and 0.06mm and Manning's $n = 0.009$

When comparing BlackMax with other pipe systems, designers should consider both the smooth surface characteristics of polypropylene and the anticipated pipeline service. Different applications may require a variation of the values of roughness coefficients chosen to conform to accepted practice. For example, much higher values are commonly specified for stormwater systems to consider anticipated debris loading. Generally, smooth pipe materials have a lower value compared with rougher materials such as cement lined pipes and concrete pipes used for the same purpose. Examples of comparative values are given in the following table.

TABLE 3.1 Comparative roughness values for different materials

Application	Polymer pipe roughness	Non polymer pipe roughness
Water	Colebrook White $k = 0.006\text{mm}$	Colebrook White $k = 0.03\text{mm}$
Stormwater drainage	Colebrook White $k = 0.06$ Mannings $n = 0.009$	Colebrook White $k = 0.6$ Mannings $n = 0.013$

Note: These values are for clean water and assume the pipeline is straight, clean, and concentrically jointed. Australian Standard AS 2200 'Design charts for water supply and sewerage' gives a range of values for Designers to select. E.g., For thermoplastics Colebrook White k is between 0.003mm to 0.015mm and Mannings n , 0.008 to 0.009 , and for concrete centrifugally spun pipes Colebrook White is between 0.03mm to 0.15mm and Mannings n , 0.009 to 0.013 .

FIGURE 3.1 BlackMax Flowchart based on the Colebrook White Equation with a Roughness Coefficient $k = 0.01\text{mm}$

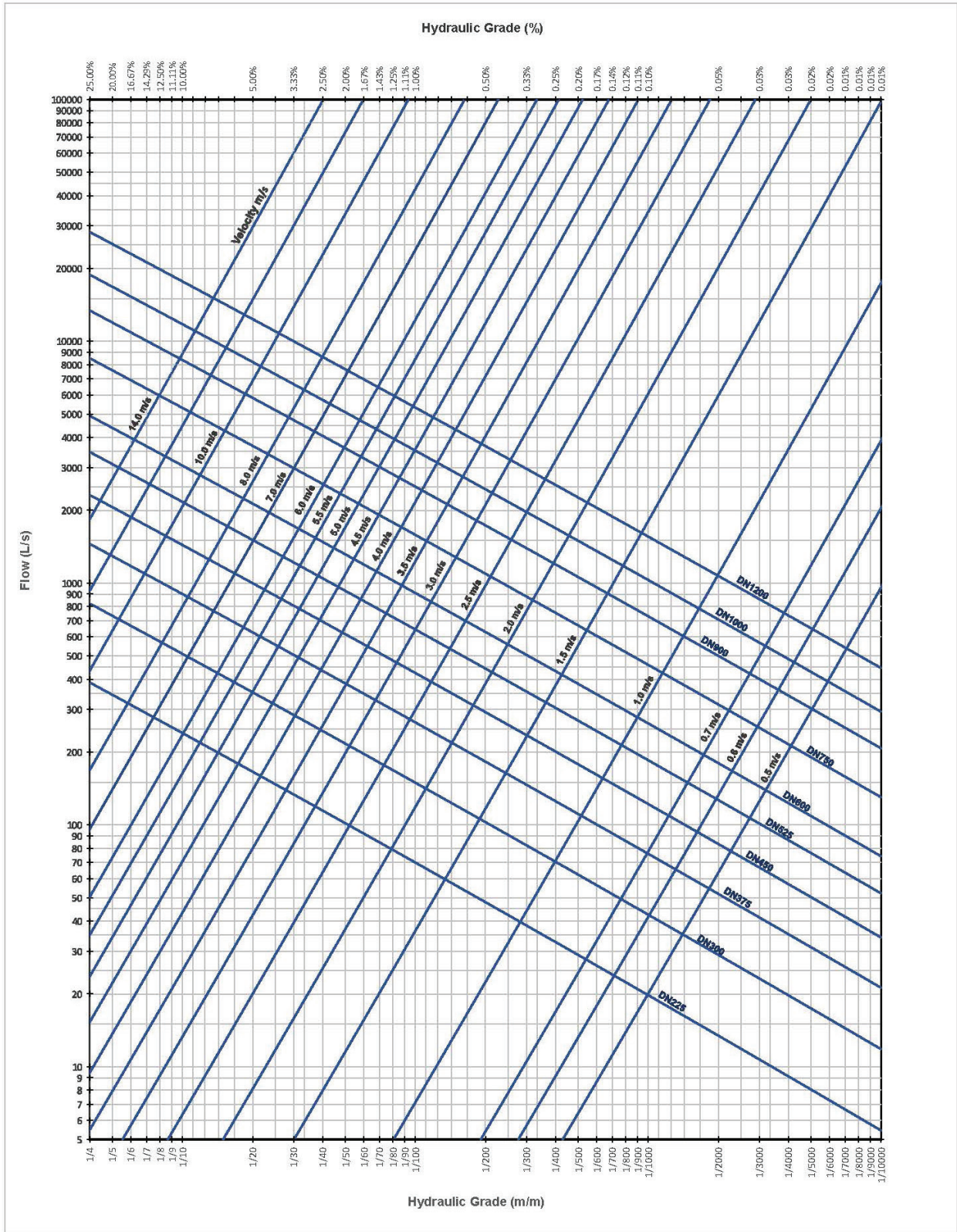

The graph shown is for guidance only.

FIGURE 3.2 BlackMax Flowchart based on the Colebrook White Equation with a Roughness Coefficient $k = 0.06\text{mm}$

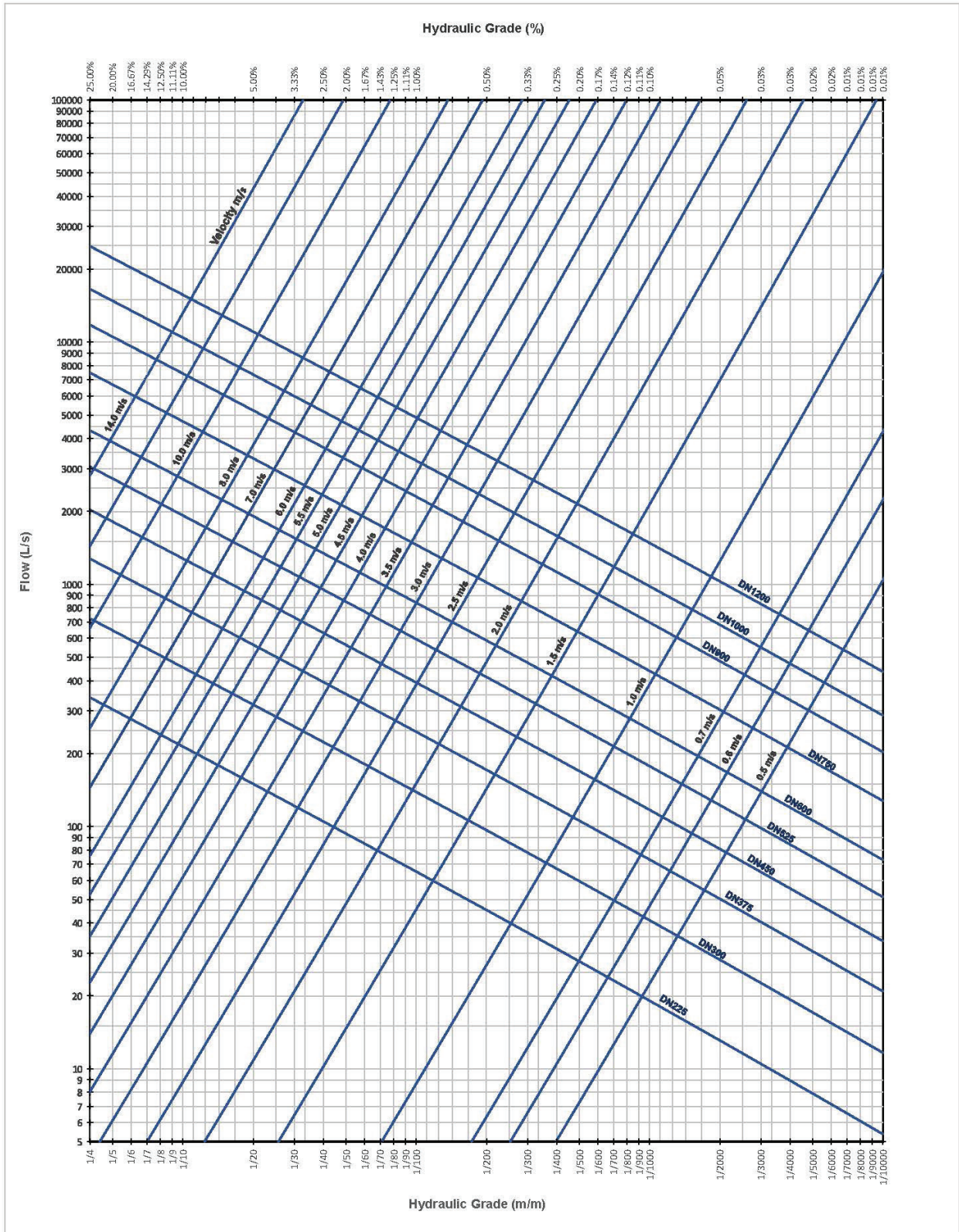

The graph shown is for guidance only.

Alternative empirical formulae, exponential in form, have been used over many years for flow calculations. Being relatively easy to use, they are still favoured by hydraulic engineers. The Manning Equations are the most common for non-pressure gravity flow. They can be written as:

Equation 3.4

$$Q = \frac{4000}{n} \pi \left(\frac{d}{4} \right)^{8/3} S^{1/2} \frac{L}{s}$$

and

Equation 3.5

$$V = \frac{0.3950}{n} d^{0.67} S^{0.5} \frac{m}{s}$$

For clean polypropylene pipes such as BlackMax, 'n' is usually taken as being equal to 0.009. In the Australian Standard AS 2200, 'n' for polymeric materials is in the range of 0.008 to 0.009 whereas for vitrified clay 'n' is in the range of 0.009 to 0.013.



FIGURE 3.3 BlackMax Flowchart based on the Mannings Equation using a Mannings n = 0.009

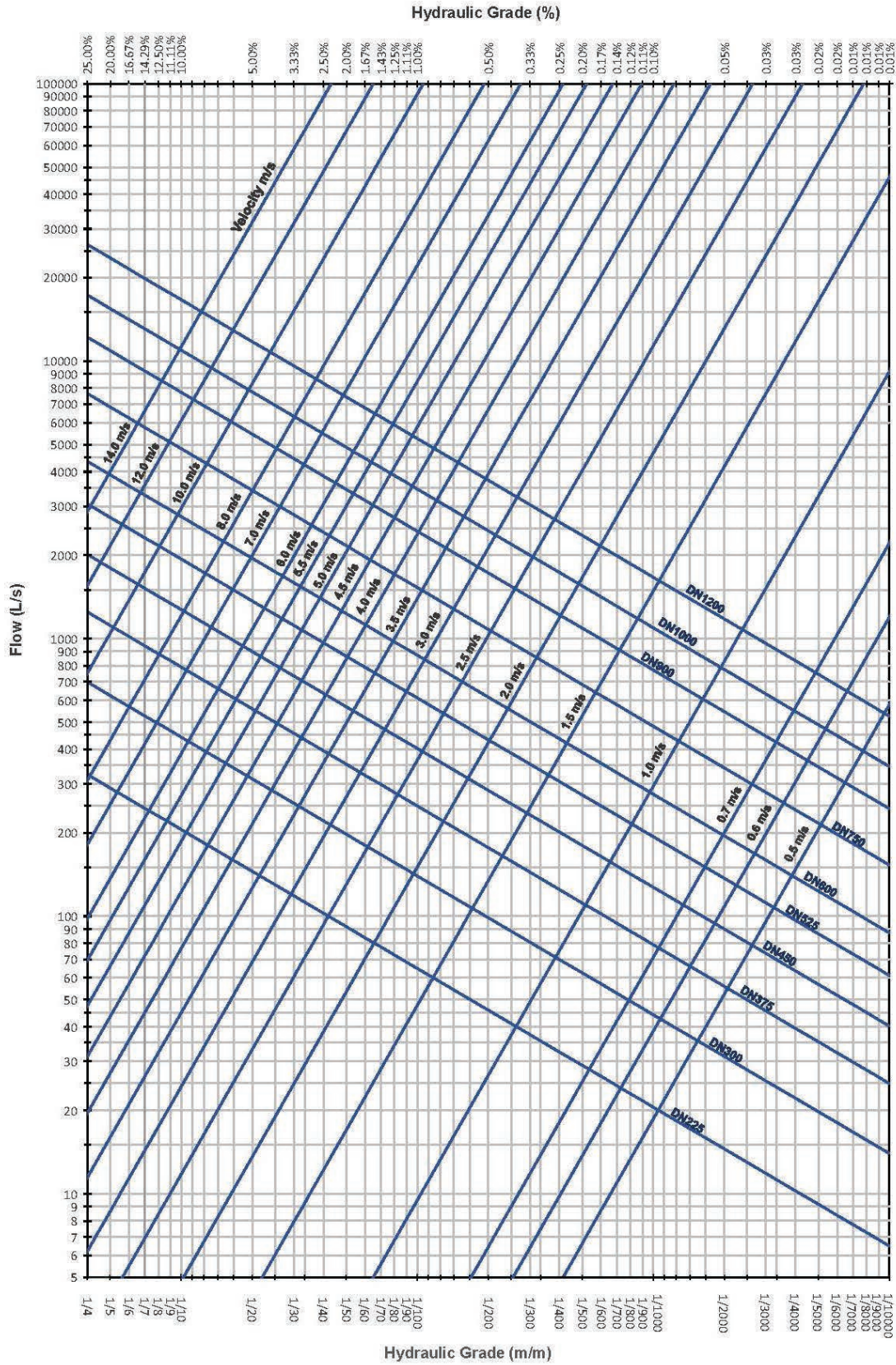

The graph shown is for guidance only.

3.1.1 STORMWATER DRAINAGE DESIGN

The design of drainage pipe networks is discussed in 'Australian Rainfall and Runoff Guidelines, Australian Government, Department of Climate change, Energy, the Environment and Water' published by the Institution of Engineers Australia. There are differences compared with other pipe system applications due to the frequency of inlets and junction pits having a significant effect on the hydraulic capacity of the system and high head losses.

Pits may be rectangular, circular, benched, or un-benched, with or without lateral pipe inlets, entries from gutters in roadways collecting surface stormwater and often involve changes in flow direction. The value for K_L in Figure 3.4 can range from 0.2 to 2.5 or greater depending on the pit configuration. Appropriate values can be obtained from ARRB Report No. 34 'Stormwater drainage design in small urban catchments' by John Argue.

Another consideration affecting flow capacity is the debris and sediment load, which is often carried in stormwater flow.

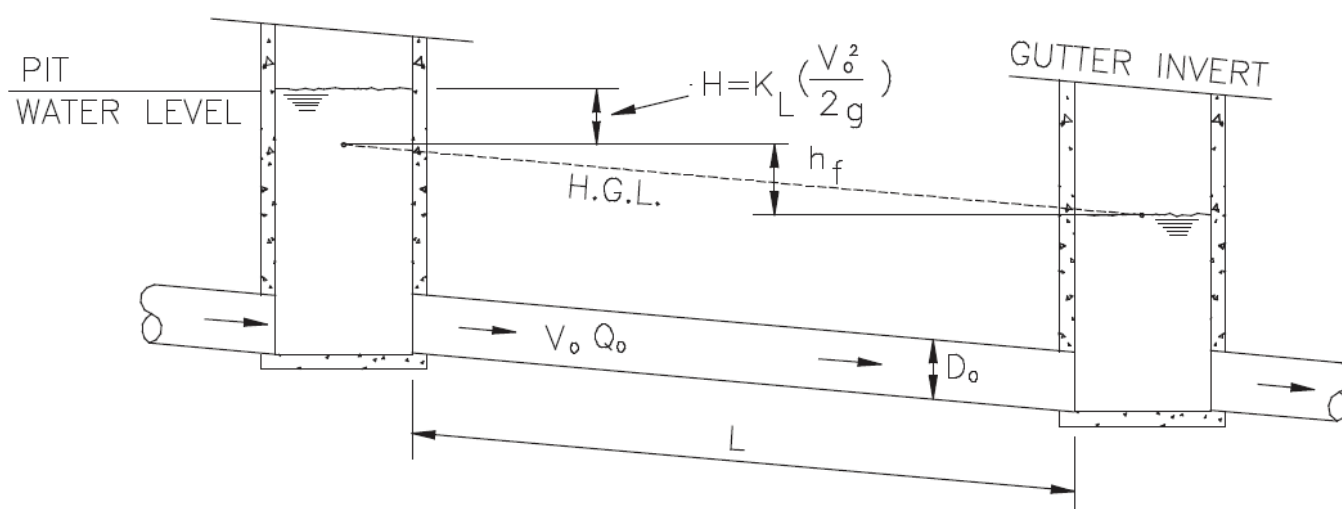

Figure 3.4 Head losses through Stormwater pits

3.1.2 VELOCITIES IN STORMWATER DRAINAGE PIPELINES - GENERAL

The minimum and maximum allowable velocities in a stormwater drainage pipeline are often specified as part of a drainage design process.

Minimum velocities are required in stormwater drains to reduce sedimentation and promote positive drainage through the pipeline at all depths. Generally, to enable a pipe to be capable of self-cleaning during dry weather flows, a minimum design flow velocity of at least 0.8m/s¹ for pipes running 1/3 full and 1m/s¹ for pipes running full is required for standard stormwater flows.

Whilst plastic pipes can carry clear water with high velocities without significant abrasion, there are other factors which indicate the need for a maximum velocity control in stormwater drains. For example, the use of other pipe materials, expected flow conditions, the type and quality of the pipe joints, stormwater pits and junctions. Therefore, stormwater drains generally have a maximum design flow velocity of 4.5m/s. Note, maximum outfall velocities are more restrictive to protect water ways and land development areas from damage and extensive erosion.

¹Melbourne Water Land Development Manual , 'Hydrologic and Hydraulic Design' Section 5.3.2 Pipe drains

3.1.3 HIGH VELOCITIES

High velocities within a drainage pipe system can cause problems and are summarised as follows:

- Abrasive wear and damage of pipe materials, fittings, and pits. Whilst this may have been a justified concern in the past with brick drains using mortar joints, modern drainage pipe materials such as polypropylene are generally less affected by abrasion in normal conditions
- Air entrapment can occur within the pipeline at high velocities which can reduce the capacity of the pipe in surcharged conditions
- Super critical flows within a drainage pipeline should be avoided. Where super critical flows are present, there is a risk of an obstruction causing a hydraulic jump and a surcharging of the pipeline
- Thrust restraints might be required in some high velocity conditions
- The inspection of pipes containing high velocity flows is unsafe and additional safety equipment and infrastructure may be required
- The discharge from the pipe outfall at high velocities can cause damage and erosion of the water body into which the pipe outfalls

Where the gradient of the pipe and the velocity is expected to be high, a flatter gradient and possibly larger diameter pipe can be installed to provide the same flow at a lower velocity. Additionally, backdrop maintenance holes can be used as energy dissipaters to reduce velocities.

While abrasion or cavitation is unlikely to be a concern, higher velocities do require additional checks on hydraulic performance such as super critical flows and greater energy losses at junctions. For this reason, any velocities above 3m/s are subjected to greater checks for normal drainage conditions. Where velocities greater than 6m/s¹ are expected, additional work should be completed to check that none of the detrimental effects including those listed in Section 3.1.3 are likely to become an issue.

¹Melbourne Water Land Development Manual , 'Hydrologic and Hydraulic Design' Section 5.3.2 Pipe drain

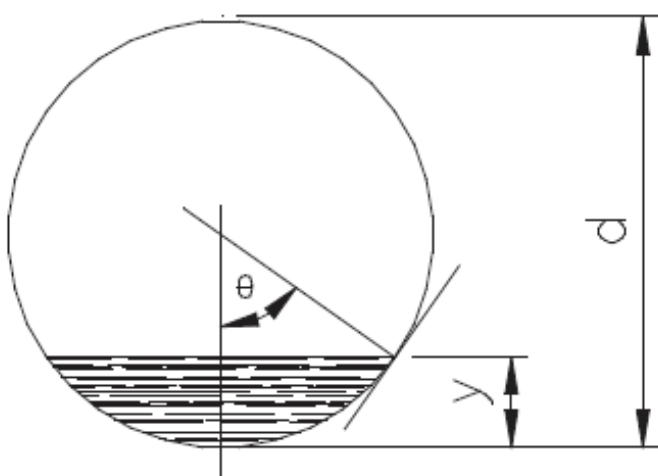

Historically, the normal design criterion was that a partial flow with a self-cleansing velocity of 0.6 m/s had to be achieved once a day. Today most design methods are based on the Fluid Boundary Layer Shear Theory. Research on the movement of sand particles on submerged pipe perimeters at low flows show that deposition will occur on the flatter parts of the pipe invert when the slope of the pipe wall is less than $\Theta = 35^\circ$ Figure 3.5. The Boundary Layer design theory builds on this fact.

From open channel theory the following expression can be written in terms of average boundary shear stress ' τ '.

Equation 3.6

$$\tau = \rho \cdot g \cdot R \cdot S \quad \text{Pascals}$$

Figure 3.5 Angle of repose of sediment for a self-cleansing flow

For a circular sewer flowing full and since $R_f = d/4$, Equation 3.6 can be written as:

Equation 3.7

$$\tau = \rho \cdot g \cdot \left(\frac{d}{4} \right) \cdot \left(\frac{R_p}{R_f} \right) \cdot S \quad \text{Pascals}$$

It can be assumed if $\tau \geq 1.5$ Pa, the pipe invert will be self-cleansing. Therefore, taking this as the value for τ , the minimum self-cleansing slope can be determined by rearranging Equation 3.7.

Equation 3.8

$$S_{min} = \frac{4\tau}{\rho \cdot g \cdot d \cdot \left(\frac{R_p}{R_f} \right)} \quad m/m$$

Using geometrical relationships and Manning's Equation 3.4, the hydraulic elements in Figure 3.6 have been developed to relate the flow, depth, and hydraulic mean radius ratios with each other. With the Q_p/Q_f ratio known, the depth to diameter ratio y/d can be found and then from this value the R_p/R_f ratio can be determined by substitution in Equation 3.8.

FIGURE 3.6 Proportional velocity and discharge in part-full pipes

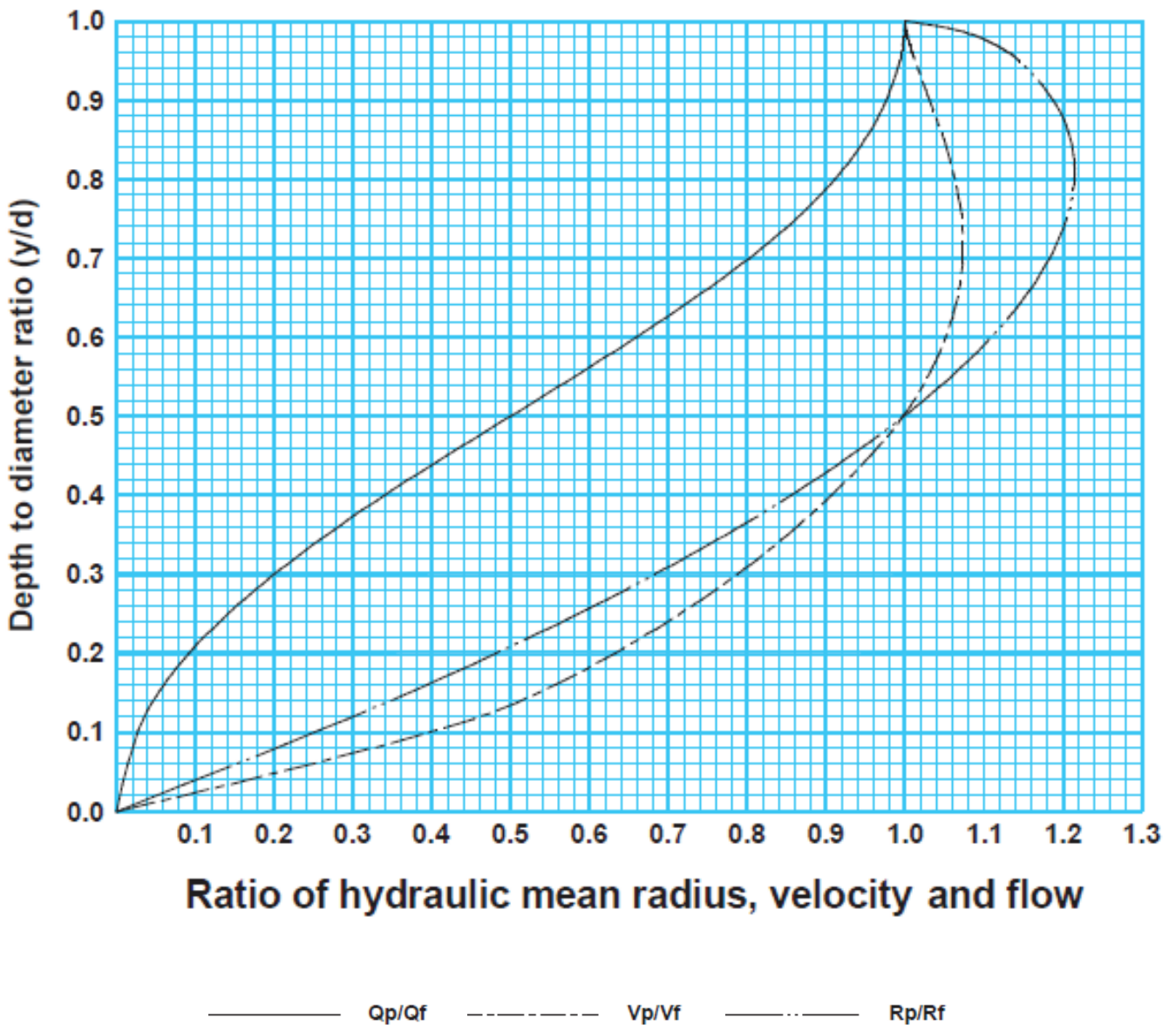

The graph shown is for guidance only.

3.2 STRUCTURAL DESIGN

In engineering terminology, BlackMax pipes are flexible pipes. They are designed to deform or deflect diametrically within specified limits without structural damage after installation.

External soil and live loads on buried flexible pipes will cause a small decrease in vertical diameter and simultaneously an increase in the horizontal diameter. The horizontal movement of the pipe walls into the soil material at the sides develops a passive resistance within the soil to support the external load. The soil type and density and height of water table (if present), all influence structural performance. The greater the effective soil modulus, the less the pipe will deflect and structural stability against buckling is also enhanced.

Information on appropriate structural design methods for buried installations is given in AS/NZS 2033 Design and installation of polyolefin pipe systems. Applicable method for assessing the predicted long-term deflection are as follows:

- i) Graphical design method which can be applied for installations meeting those parameters defined in clause 6.2.2.1 of AS/NZS 2033.
- ii) Engineering structural design method as specified in AS/NZS 2566.1 'Buried flexible pipelines Part 1 - Structural design and Supplement.

BlackMax pipes are classified by their pipe stiffness (Table 3.2) and are suitable for a range of cover heights. (Figures 3.11 to 3.14).

TABLE 3.2 BlackMax pipe stiffnesses and Classifications.

Pipe	Pipe Stiffness	Classification
BlackMax	>8000 N/m/m	SN8

To properly assess the effects of site conditions on a proposed installation, specific information is needed for structural design.

This includes:

- Pipe diameter (m)
- Cover height (m)
- Properties of Native soil at pipe depth
- Width of Embedment (m)
- Properties of Embedment material
- Height of Water table (m)
- Traffic loading
- Special requirements, such as concrete encasement or grouting

Important Note:

Professional advice should be obtained to determine the appropriate value of the effective soil deformation modulus for an installation. It will depend on the native soil type and condition, the pipe embedment material, its degree of compaction and its geometry (e.g. trench width and embedment width).

Geotechnical surveys giving soil types and properties, including soil-bearing capacities, SPT (Standard Penetration Test) values at pipe depth and embedment compaction will be relevant to the design.

The following notations are used in this Section:

Notation	Description	SI unit
a	The radius of applied circle of loading	m
b	Embedment width on each side of the pipe at spring line	m
B	Trench width at the pipe spring-line	m
D	Overall outside diameter of the pipe	m
E'_e	Embedment soil deformation modulus	MPa
E'_n	Native soil deformation modulus	MPa
E'	Combined soil deformation modulus	MPa
H	Cover height	m
h	Bedding thickness	m
k	Overlay thickness	m
p	Presumptive (allowable) bearing pressure	kPa
Δ	Displacement or settlement	m
ξ	Leonhardt factor	

FIGURE 3.7 Critical dimensions for design and installation

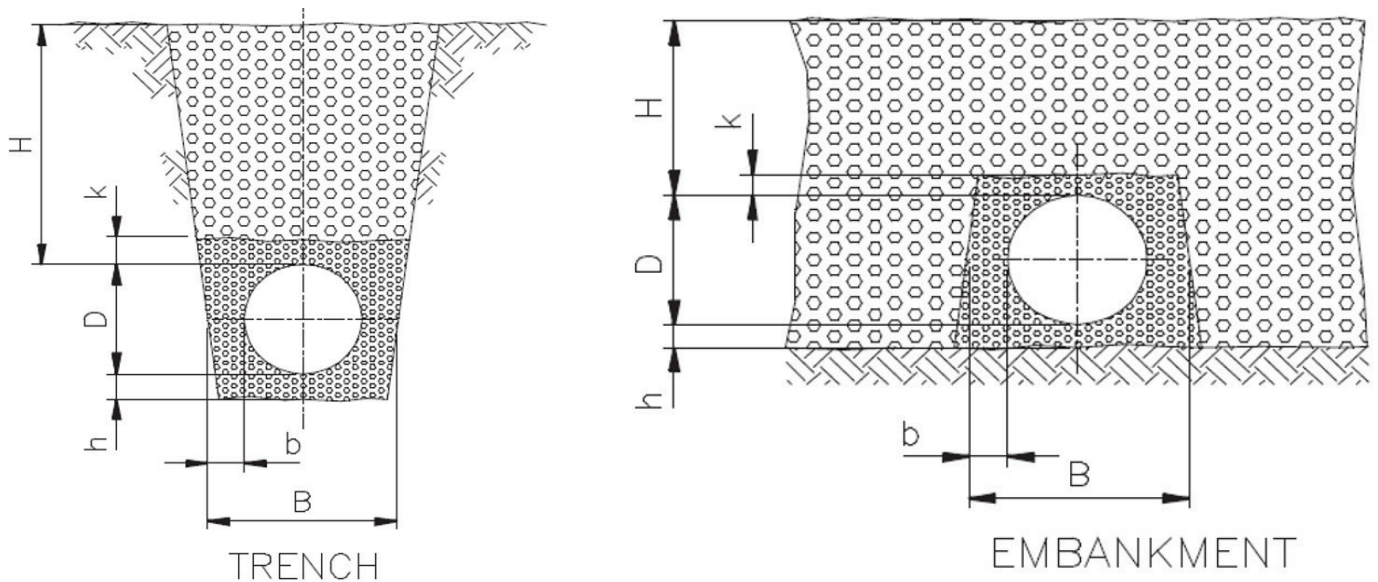

B = trench width at spring line, D = external pipe diameter

3.2.1 GEOTECHNICAL INVESTIGATION

The conventional approach to a pipeline route investigation has been to assess the soil conditions at pipe depth by carrying out a drilling and soil sampling program along the alignment. While the intention in the past was often only to determine the presence of rock and to estimate trench stability for construction purposes, this investigation is now used for more detailed geotechnical reporting and includes additional information readily obtained from routine surveys. It includes design data such as the Standard Penetration Test (SPT), blow counts (at pipe depth), identification of native soil type and depth of water table. The designer will also require an assessment of the embedment material surrounding the pipe and the specified compaction procedure.

3.2.2 DERIVATION OF SOIL DEFORMATION MODULUS VALUES

The correct choice of soil moduli will have significant effects on design decisions. An approximate conversion of SPT blow counts to soil moduli is given in Table 3.2 of Australian Standard AS/NZS 2566.1. Often this is contained in records obtained over many years and frequently gives correlations between SPT and allowable soil bearing pressures.

The soil deformation moduli stated in AS/NZS 2566.1 were originally derived from European design practice using soil bearing plate tests. These moduli are generally about half the value of deformation moduli measured using standard laboratory tri-axial tests and should not be confused with these. Using allowable foundation bearing pressures, it is possible to derive the plate load or pipe design soil moduli from the Boussinesq's plate bearing theory for an elastic, homogenous, isotropic solid. That is for a rigid plate and a soil Poisson's ratio of 0.5.

For the purposes of obtaining a derivation, it can be assumed that the plate is a standard 750mm diameter and the allowable settlement is 15mm. Equation 3.9 provides a conversion relationship, $E'_n = 0.03p$. Table 3.3, which is based on data published by Sowers¹ (1979), shows the result of applying this factor. Similarly Figures 3.8 and 3.9 give deformation moduli obtained by converting other published data (Hough 1959, Clegg 1996).

Values of the soil deformation moduli are needed for both the native and embedment soils within 2.5 x the pipe diameter on each side of the pipe centreline. The modulus for a given pipe embedment soil E'_e can be estimated from Table 3.4.

Equation 3.9

$$\Delta = \frac{1.18.p.a}{E'_n} \cdot 10^{-3} \quad m$$

FIGURE 3.8

Estimated soil deformation moduli for Clays and Mixed soils

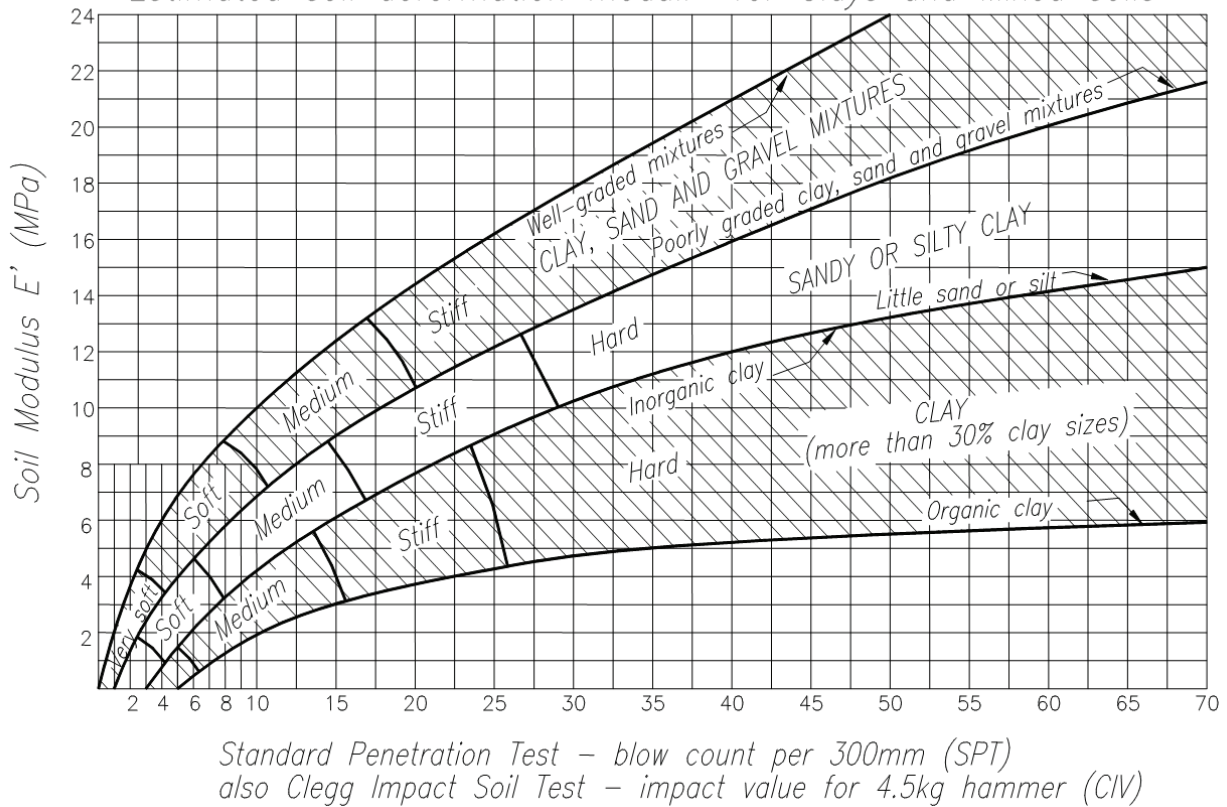

The graph shown is for guidance only.

FIGURE 3.9

Estimated soil deformation moduli for granular soils

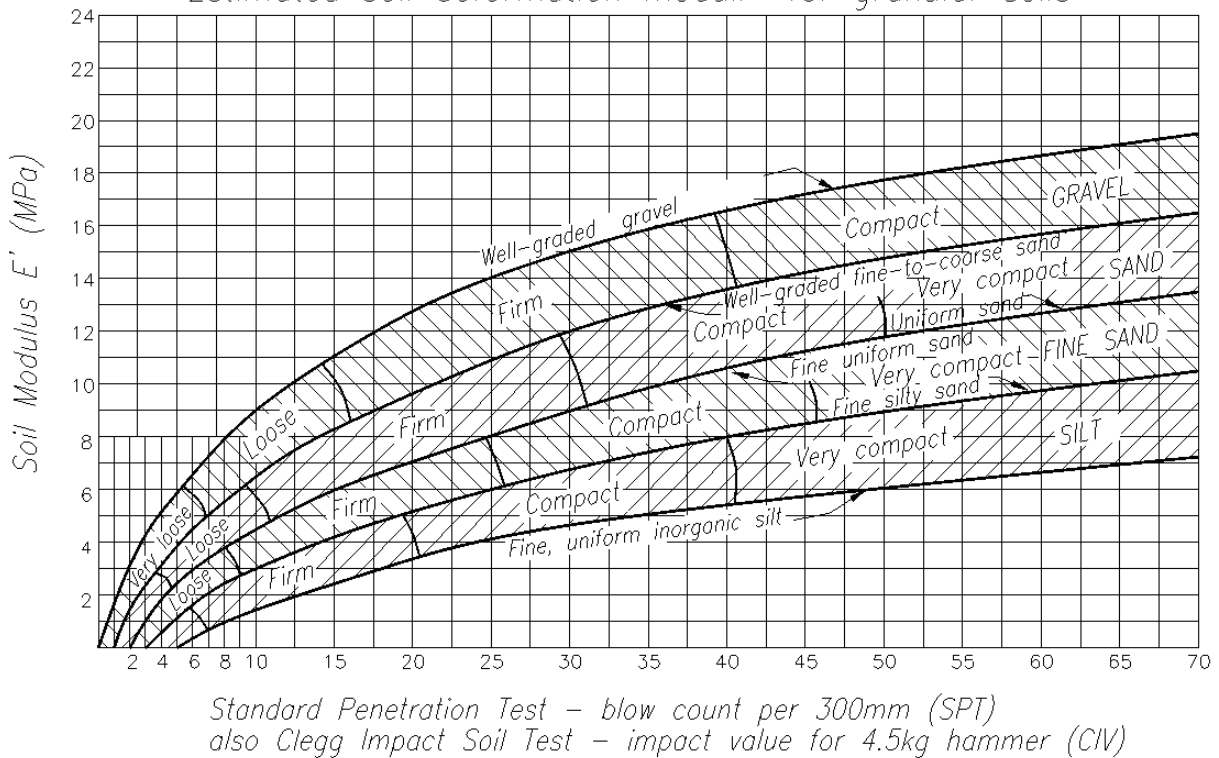

Note! Saturated silts and sands will have strength reduced by approximately 50% over "dry" or "moist" conditions

The graph shown is for guidance only.

TABLE 3.3 Typical allowable foundation pressures converted to native soil moduli

Soil Description	Standard Penetration Resistance – blow count over 300 mm	Allowable foundation bearing pressures p (kPa)	Derived soil deformation moduli E'_n using Eq 3.7 (MPa)
Loose sand, dry	5 - 10	70 - 140	2.1 – 4.2
Firm sand, dry	11 - 20	150 – 300	4.5 – 9.0
Dense sand, dry	31 – 50	400 – 600	12 – 18
Loose sand, inundated	5 – 10*	40 – 80	1.2 – 2.4
Firm sand, inundated	11 – 20*	80 – 170	2.4 – 5.1
Dense sand, inundated	31 – 50*	240+	7+
Soft clay	2 – 4	30 – 60	0.9 – 1.8
Firm clay	5 – 8	70 – 120	2.1 – 3.6
Stiff clay	9 – 15	150 – 200	4.5 – 6.0
Hard clay	30+	400+	12+
Heavily fractured or partially weathered rock	50+	500 - 1200	15 - 36

TABLE 3.4 Embedment soil moduli

*SPT before inundation		Soil Description	Standard dry density ratio (%)	Density Index (%)	Deformation moduli E'_s (MPa)
Aggregate – single size	-			Uncompacted	5
				50	6
				60	7
				70	10
Aggregate - graded	-			Uncompacted	3
				50	5
				60	7
				70	10
Crushed rock				Uncompacted	1
				85	3
				90	5
				95	7
Sand and coarse-grained soil with less than 12% fines				Uncompacted	1
				85	3
				90	5
				95	7
Coarse grained soil with more than 12% fines				85	1
				90	3
				95	5

*Note: These values are given in AS/NZS2566.1 - Buried Flexible Pipelines, Part 1 Structural Design

3.2.3 EFFECTIVE SOIL MODULUS

Knowing the proportion of embedment and native soil in the side support zone, trench width to pipe diameter (B/D) and the ratio of embedment modulus to native soil modulus (E'_e/E'_n), the Leonhardt factors ξ given in Table 3.5 enable an overall effective soil modulus E' to be determined using the equation:

Equation 3.10

$$E' = \xi E'_e \quad \text{MPa}$$

TABLE 3.5 Leonhardt correction factor ξ

B/D	E'_e/E'_n						
	0.2	0.4	0.8	1	2	4	6
1.5	2.4	1.8	1.2	1.0	0.6	0.3	0.2
2.0	1.7	1.5	1.2	1.0	0.6	0.4	0.3
2.5	1.5	1.3	1.1	1.0	0.7	0.5	0.4
3.0	1.2	1.2	1.0	1.0	0.8	0.6	0.5
4.0	1.0	1.0	1.0	1.0	1.0	0.9	0.8
5.0	1.0	1.0	1.0	1.0	1.0	1.0	1.0

TABLE 3.6 Trench widths and pipe spring-line

DN	Trench width* at the pipe spring-line 'B' (Figure 3.5)
225	Overall outside diameter of the pipe 'D' + 0.3m
300	
375	
450	Overall outside diameter of the pipe 'D' + 0.4m
525	
600	Overall outside diameter of the pipe 'D' + 0.6m
750	
900	
1000	Overall outside diameter of the pipe 'D' + 0.7m
1200	

*Note: The objective is to achieve uniform compaction of the embedment material. The trench widths might provide insufficient clearances for installation purposes in certain circumstances.

TABLE 3.7 Minimum cover heights*

Location	Minimum height of cover H (m)
Not subject to vehicular loading	0.30
Subject to vehicular loading	
- not in roadways	0.45
- in sealed roadways	0.60
- in un-sealed roadways	0.75
Pipes in embankment conditions or subject to construction equipment loading	0.75

*AS/NZS2566.1 Buried flexible pipelines Part 1: Structural design

Figures 3.10 to 3.14 below are applicable for BlackMax SN8 pipes with the following pipe design parameters, and give an estimate of Maximum safe cover heights.

- Minimum Trench widths in accordance with AS/NZS 2566.1
- Maximum long-term vertical pipe deflection 7.5%
- Buckling factor of safety of 2.5
- SM1600 Traffic loading
- Density of trench fill over the pipe 20kN/m³

Assuming a density of 20kN/m³ for the trench fill over the pipe, **Figures 3.10 to 3.14**, will then give an estimate of the Maximum safe cover heights.

FIGURE 3.10

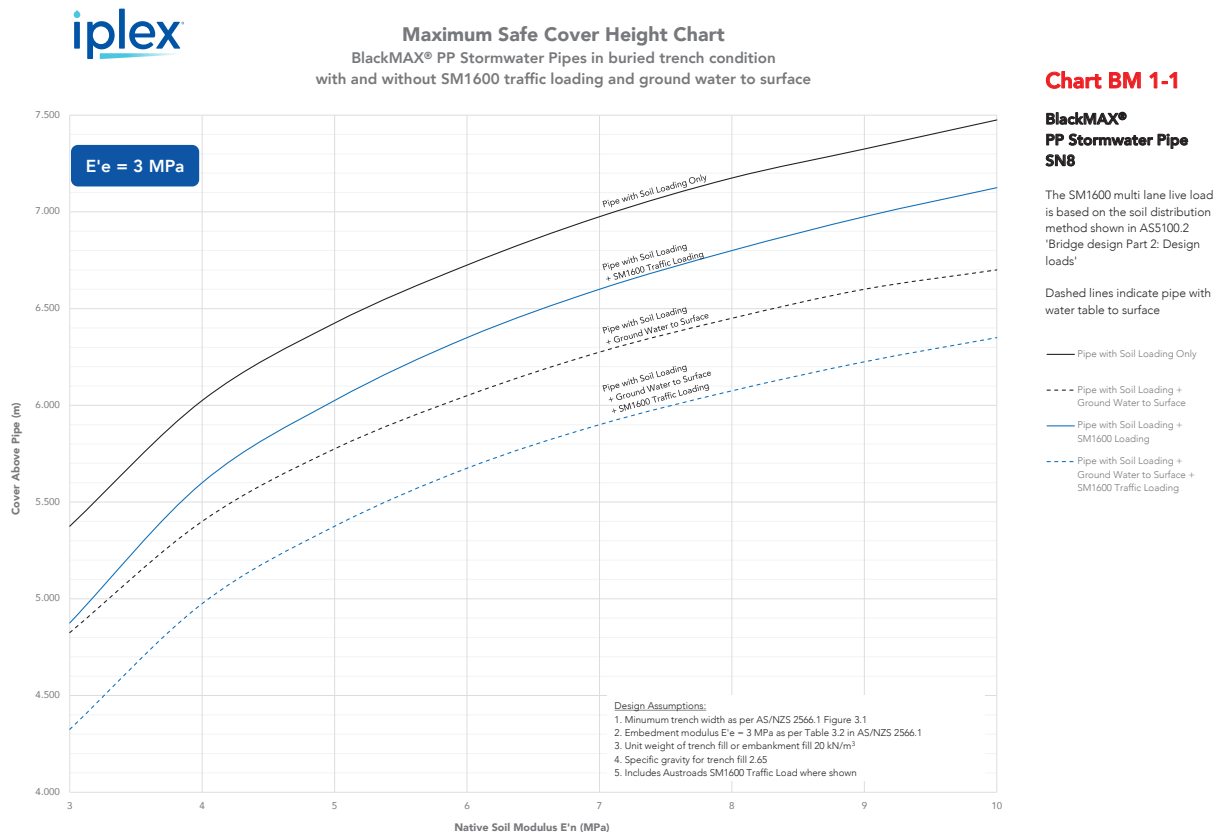

The graph shown is for guidance only.

FIGURE 3.11

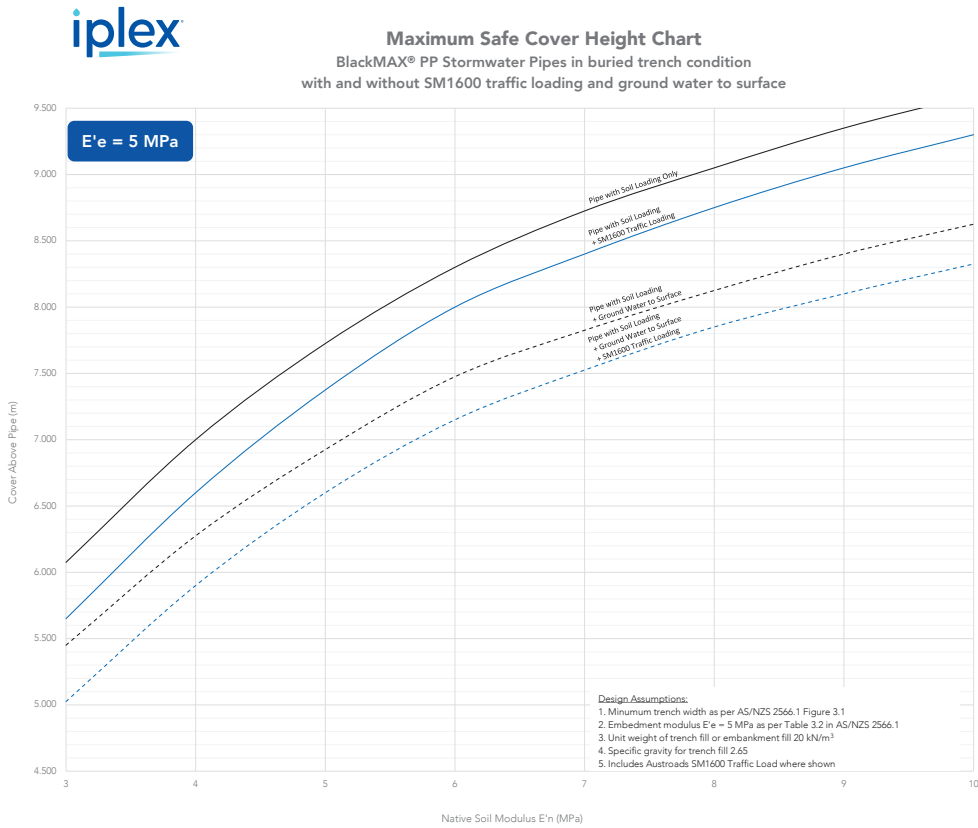

Chart BM 1-2

**BlackMAX®
PP Stormwater Pipe
SN8**

The SM1600 multi lane live load is based on the soil distribution method shown in AS5100.2 'Bridge design Part 2: Design loads'

Dashed lines indicate pipe with water table to surface

- Pipe with Soil Loading Only
- - - Pipe with Soil Loading + Ground Water to Surface
- Pipe with Soil Loading + SM1600 Traffic Load
- - - Pipe with Soil Loading + Ground Water to Surface + SM1600 Traffic Loading

The graph shown is for guidance only.

FIGURE 3.12

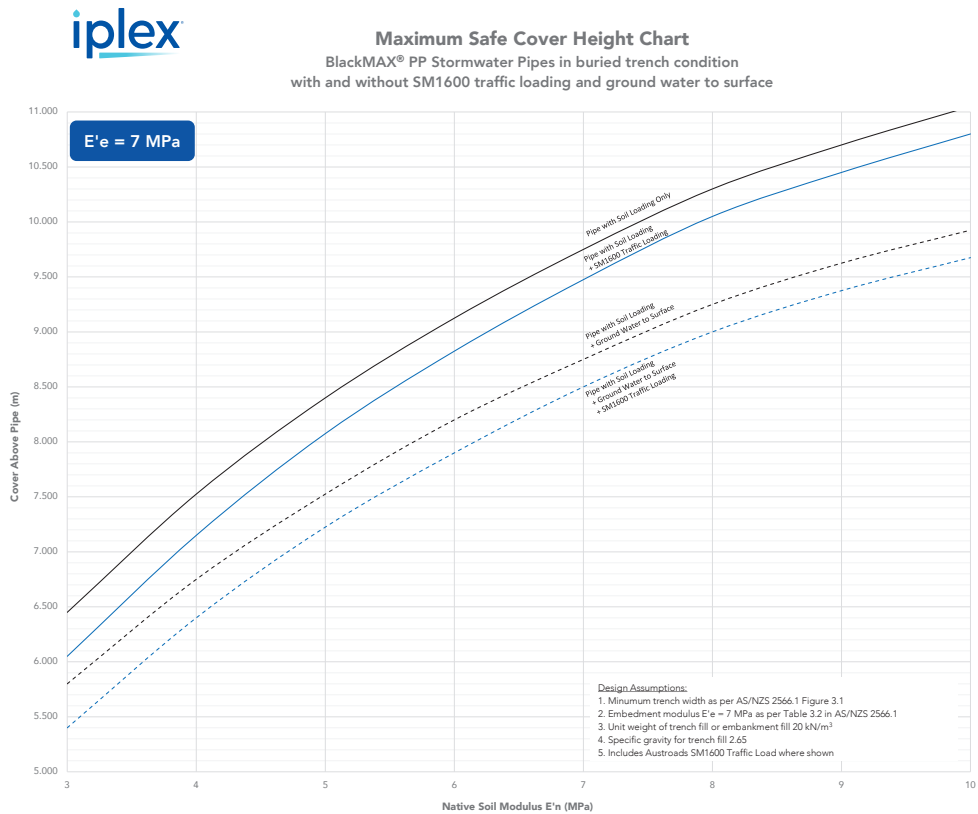

Chart BM 1-3

**BlackMAX®
PP Stormwater Pipe
SN8**

The SM1600 multi lane live load is based on the soil distribution method shown in AS5100.2 'Bridge design Part 2: Design loads'

Dashed lines indicate pipe with water table to surface

- Pipe with Soil Loading Only
- - - Pipe with Soil Loading + Ground Water to Surface
- Pipe with Soil Loading + SM1600 Traffic Load
- - - Pipe with Soil Loading + Ground Water to Surface + SM1600 Traffic Loading

The graph shown is for guidance only.

FIGURE 3.13

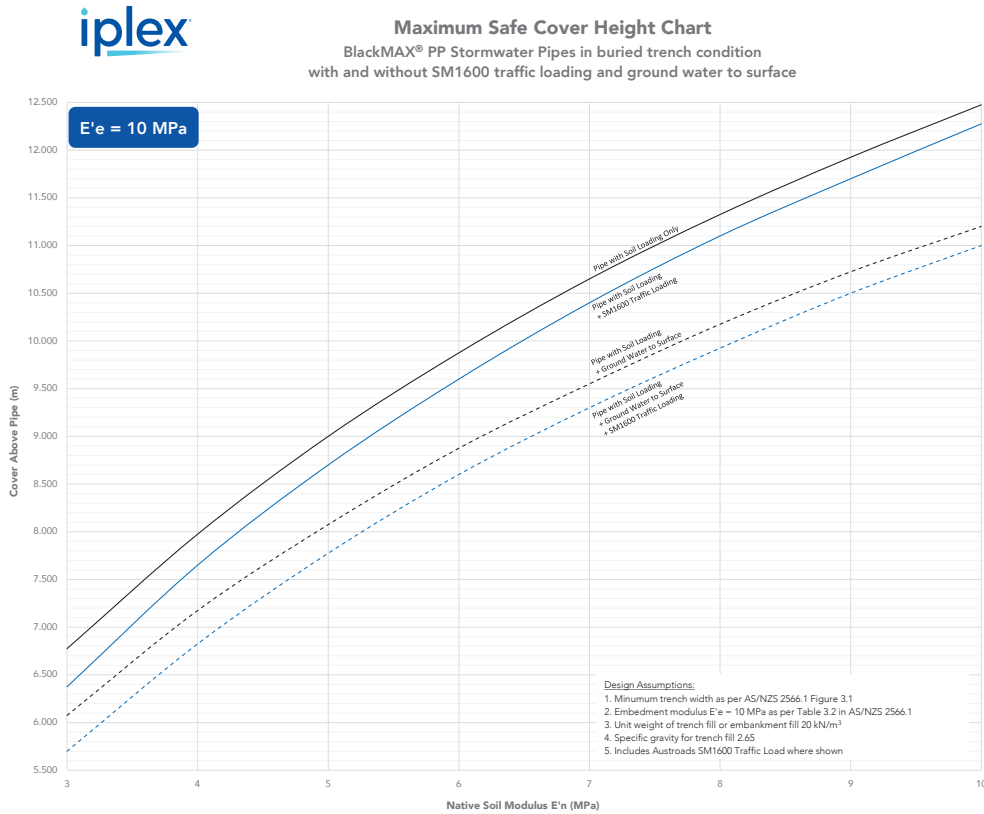

The graph shown is for guidance only.

Chart BM 1-4

**BlackMAX®
PP Stormwater Pipe
SN8**

The SM1600 multi lane live load is based on the soil distribution method shown in AS5100.2 'Bridge design Part 2: Design loads'

Dashed lines indicate pipe with water table to surface

- Pipe with Soil Loading Only
- - - Pipe with Soil Loading + Ground Water to Surface
- Pipe with Soil Loading + SM1600 Traffic Loading
- - - Pipe with Soil Loading + Ground Water to Surface + SM1600 Traffic Loading

FIGURE 3.14

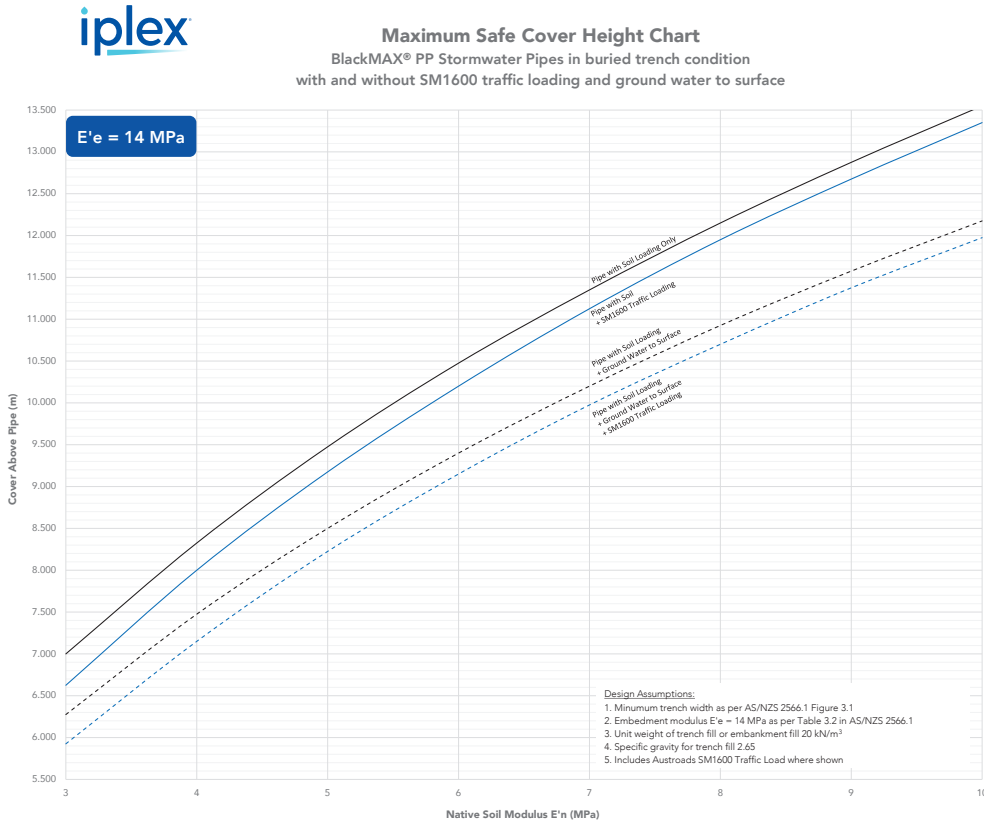

The graph shown is for guidance only.

Chart BM 1-5

**BlackMAX®
PP Stormwater Pipe
SN8**

The SM1600 multi lane live load is based on the soil distribution method shown in AS5100.2 'Bridge design Part 2: Design loads'

Dashed lines indicate pipe with water table to surface

- Pipe with Soil Loading Only
- - - Pipe with Soil Loading + Ground Water to Surface
- Pipe with Soil Loading + SM1600 Traffic Loading
- - - Pipe with Soil Loading + Ground Water to Surface + SM1600 Traffic Loading

3.2.4 EFFECTS OF CONSTRUCTION LOADS ON BURIED BLACKMAX (PP) PIPES

The recommended minimum (final) cover heights for buried flexible pipelines in different installation conditions are tabulated in Australian Standard AS/NZS 2566.2 and are empirically derived from accepted installation practice. They are similar for rigid pipes.

However, some government authorities have requested information on the performance of flexible pipes under construction loads where cover heights may be considerably lower. A theoretical evaluation is possible using the design procedures for flexible pipes given in AS/NZS 2566.1 Clause 4.7 'Super-imposed Live Loads' provided that these covers may be less than the prescribed design minimum. That is at covers less than 400mm where loads are due to compaction equipment, it is reasonable to assume there will be some load dispersion, but this will reduce progressively in a linear fashion to zero, as covers reduce from 400mm to zero.

Minimum (construction) cover heights have been calculated using this approach. Assumptions have been made with the native soil modulus values of 3MPa being considered appropriate. This corresponds to a firm clay with a presumptive foundation bearing pressure of about 100kPa or SPT blow count of 6+ per 300mm. A firm inundated sand would have a similar modulus. The embedment modulus has been taken to be 7MPa from AS/NZS 2566.1 as this is typical of good quality embedment material. The calculated minimum covers for the range of compaction equipment are given in Table 3.8 .

TABLE 3.8 Compaction equipment with minimum cover heights calculations $B/D \geq 1.66$

Type	Vibratory Rammer (75kg)	Vibratory Trench Roller (2T)	Excavator compaction wheel (25T)	Vibratory Smooth drum Roller (17T)	Vibratory Smooth drum Roller (7T)	Vibrating Plate (240kg)
Model	BS62Y			CAT CS653		
Number of axles	1	2	1	1	1	1
Axle spacings	N/A	970mm	N/A	N/A	N/A	N/A
Bearing length 'a'	330mm	200mm	200mm	200mm	100mm	500mm
Bearing length 'b'	330mm	865mm	580mm	2200mm	1676mm	500mm
Wheel load 'P'	33kN	72kN	155kN	218kN	162kN	37kN
Minimum Cover Heights using compaction equipment (mm)						
Pipe Stiffness (N/m/m)	Vibratory Rammer (75kg)	Vibratory Trench Roller (2T)	Excavator compaction wheel (25T)	Vibratory Smooth drum Roller (17T)	Vibratory Smooth drum Roller (7T)	Vibrating Plate (240kg)
SN8	300mm	425mm	850mm	650mm	625mm	200mm

On site, the effect of compaction equipment on flexible pipes can be checked by monitoring changes in ring deflection. Details of allowable deflections are given in Clause 5.7 of AS/NZS 2566.2. Although higher ring deflections will not damage polypropylene pipes, excessive initial ring deflections, e.g. more than 4%, must be avoided as the magnitude of the deflection after installation is often used as the prime indicator of whether the specified side support compaction has been achieved. Compaction of the side support zone before allowing the compaction equipment to operate on the overlay above the pipe will assist in this respect. Where the allowable limit has been exceeded the pipeline installation may be rejected. In these circumstances it may be acceptable to recover and re use the same pipes with increased side support compaction.

PocketENGINEER™ Structural Design Tool

To assist designers with the specification of structurally effective flexible pipeline installations, Iplex has developed a web based flexible pipe structural design tool. Alongside several other helpful design tools, this is accessible to customers via the Iplex PocketENGINEER™ portal (www.pocketengineer.com.au).

The structural design tool considers project specific inputs such as pipe types and sizes, trench and loading conditions and advises if the installation design meets the relevant requirements of AS2566.

A design report can be prepared and shared with other PocketENGINEER™ users for review. Various saved designs can also be collated into a useful comparison report to help establish the most efficient system possible.

To access the tool, simply visit www.pocketengineer.com.au to register.

4.0 INSTALLATION

4.1 PLANNING

Some thought and care must be given in preparing the site prior to receiving the pipes and fittings. Choose flat areas for pipe storage with safe vehicle access and ensure that it is possible to safely unload the pipes and fittings at the sites you have chosen. For example, crane trucks near overhead powerlines. [Refer to Iplex's 'Exclusion Zones at Customer Sites' document for guidance which is available at www.iplex.com.au.](#)

Note: The pack sizes and weights can be large and heavy, and will require suitable lifting equipment and machines to complete unloading safely.

4.2 TRANSPORTATION AND STORAGE

Storing pipes correctly will limit any damage and help lead to safe working practices. Tins of pipe jointing lubricants must be stored securely, preferably in a lockable shed or container

attached with their chemical safety data sheet . Petroleum products, solvents and greases can damage rubber products and must not be stored with rubber sealing rings.

When receiving the load at the job site, check the timber packs. Wear puncture and cut proof gloves for protection against protruding nails. If the timber packs are broken and/or have moved, inspect each pipe for damage. Any damaged or missing items must be noted and quarantined for inspection.

4.3 UNLOADING

Before unloading pipes and fittings, it is critical that exclusion zones are implemented between the mobile plant and people on site.

Unloading packed pipes and loose pipes will require care to protect the loads and provide safety for the workers. Use approved and suitable lifting equipment. For example, forklift with padded tynes, crane, backhoe, or excavator with certified and currently tagged nylon slings.

Always follow safe unloading requirements. Forklift and attachments must be load rated to suit the lifting requirements and attachment lengths of the product being unloaded. For example, ensure the length of the tynes **DO NOT** push against the adjacent crates and or pipes on the far side of the truck. Do not stand under or near the pipe pack, pipe or fitting that is being lifted. Enforce **SAFE** exclusion zones around the pipes and fittings being lifted. If unsure speak with the forklift manufacturer for advice and information for your needs.

Webbing slings must be placed under and around the pipe pack. Do not use the pack’s frame or straps for lifting. It is not designed for unloading.

Avoid climbing on the pipes for safety reasons. The surface can be slippery especially in wet or frosty conditions.

4.4 HANDLING

When handling BlackMax pipes and fittings always wear approved Personal Protective Equipment (PPE).

Although BlackMax pipes are notably resistant to impact, they must not be rolled, dropped, thrown, or encounter

sharp objects likely to cause damage. Always avoid impact loads and always lower the pipes to the ground carefully.

When pipes are unloaded for storage they must be kept in their packs until required. The storage site must be level and free of obstructions. Allow enough space in between each pipe pack for lifting equipment to safely manoeuvre without causing accidental damage.

If pipes are not crated, they must be kept on horizontal supporting timbers at approximately 2 metre centres. These timbers can also be used to separate layers when pipes are stacked individually, which will facilitate the safe placement and removal of currently tagged and certified lifting slings.

Stack heights must be limited to prevent excessive deformation. **ALL PIPES MUST BE RESTRAINED TO PREVENT ROLLING BY UNEVEN GROUND, WIND LOADS OR OTHER EXTERNAL FORCES.**

Sockets must be protected from distortion during storage by ensuring all the sockets are placed at alternate ends and raised clear from ground and each other.

TABLE 4.1 Pack specifications for BlackMax pipes

DN	Approximate pack sizes			Pipes per pack (No)	Approximate mass of pack (Without timbers) (kg)	Pipes per semi-trailer
	Width (mm)	Height (mm)	Length (mm)			
225	1100	610	6300	8	176	128
300	1100	770	6330	6	216	72
375	920	940	6400	4	204	60
	or 1345			6	306	
450	1130	595	6500	2	152	32
525	1890	715	6500	3	276	24
600	2130	770	6500	3	360	18
750	1786	931	6835	2	362	12
900	2120	1098	7120	2	490	8
1000	TBC*	TBC*	TBC*	TBC*	TBC*	TBC*
1200	TBC*	TBC*	TBC*	1	484	TBC*

*Contact Iplex for further details.

4.5 INSTALLATION GUIDELINES

BlackMax are flexible pipes which are designed for controlled deflection under vertical soil loads. These loads are transferred to the soil in the side support zone, providing a very efficient pipe to soil interaction and high structural performance. Australian Standard AS/NZS 2566.2 'Buried flexible pipelines -Part 2 Installation' provides detailed information on appropriate methods for ensuring the side support zone is correctly constructed.

The most critical aspect for the successful installation of these pipes is the selection and compaction of the embedment, i.e. the material in contact with the pipe. Embedment material must be of a granular nature, which is readily compactable. Crushed rock, aggregate and graded sand are commonly used but occasionally native soils, (e.g. beach and Mallee sand) may also be suitable provided they are free flowing and readily compacted and provide permanent support over the service life of the pipeline. Appendices G and H of AS/NZS 2566.2 provide extensive guidance on the selection and use of a wide range of embedment materials.

FIGURE 4.1 Buried pipeline terminology

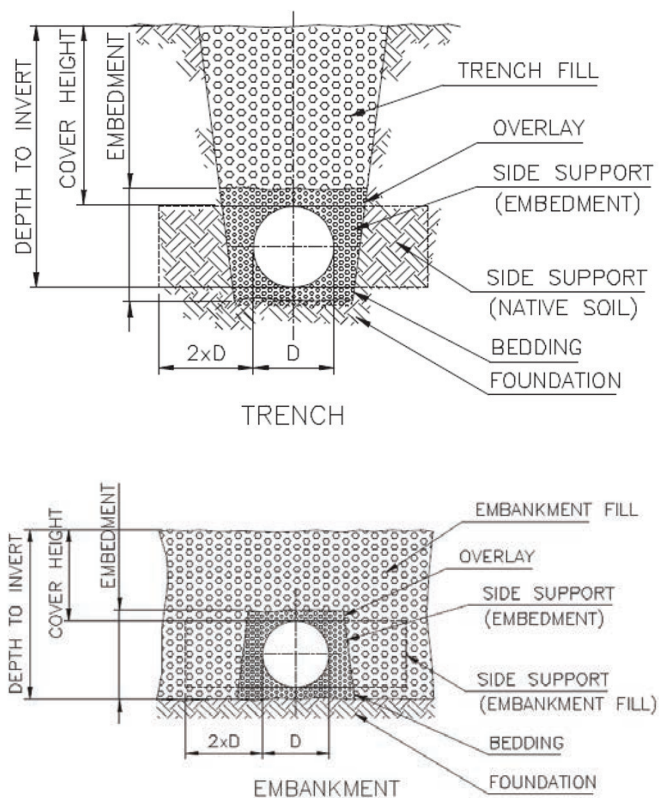

4.6 EXCAVATION AND ASSOCIATED WORKS

4.6.1 TRENCH EXCAVATION

Excavate the trench to the line and grade specified. The trench width must be enough to permit compaction of the pipe embedment materials with suitable equipment. The minimum pipe trench width required is dependent on the pipe diameter. Refer to Section 3.2.3, Table 3.6 for further information. The trench bottom must be even and free of soil clods and rocks.

4.6.2 FOUNDATION

The native soil in the foundation zone must be carefully excavated to grade permitting the pipeline to be correctly aligned and allowing for bedding material with a minimum thickness of 100mm (DN225 to DN375) and 150mm (DN450 to DN1200) beneath the pipe. If the bearing capacity of the foundation soil is thought to be less than 50 KPa it will need to be replaced with a mattress of embedment material. In this situation, geotechnical advice should be obtained.

4.6.3 UNSTABLE AND WET GROUND CONDITIONS

Wet and/or unstable soil conditions will require precautions to maintain firm and permanent side support for the pipes once installed. Where groundwater is present, there may be a risk of the fine soil particles migrating across the interface between the native and embedment soils. In this situation the embedment must be fully enveloped with geo-textile material. Details of soil gradings where this can occur are given in AS/NZS 2566.2.

Pipe installation must be carried out in a trench free of water. Where there is continuous ground water inflow, it will be necessary to facilitate drainage of the trench with approved dewatering equipment and using a porous layer of bedding material in the foundation zone.

Generally, this will be a coarse granular material, which will need to be fully encapsulated in a geo-textile fabric. It is sometimes described as a drainage mattress.

4.6.4 TRENCH SHIELDS

Trench shields or soil boxes must be a close fit against the excavated trench walls and the bottom edges kept above the top of the pipe. If for safety reasons they must extend to the bottom of the trench, compaction of the embedment material after the shields are lifted will be necessary to eliminate any voids that may otherwise develop (see Figures 4.2 and 4.3).

Trench shields used in open excavations are prone to accumulate loose debris between the box and the trench wall. As this poor-quality material can adversely affect the available side support, it is good practice to place high quality embedment material to form part of the side support zone as soon as possible. This will exclude any debris or material which may slough from the trench wall (see Figure 4.4).

FIGURE 4.3 Shields kept below pipe during installation

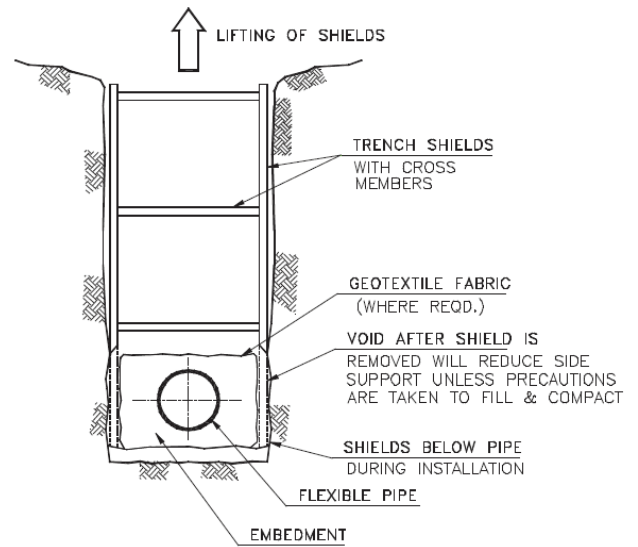
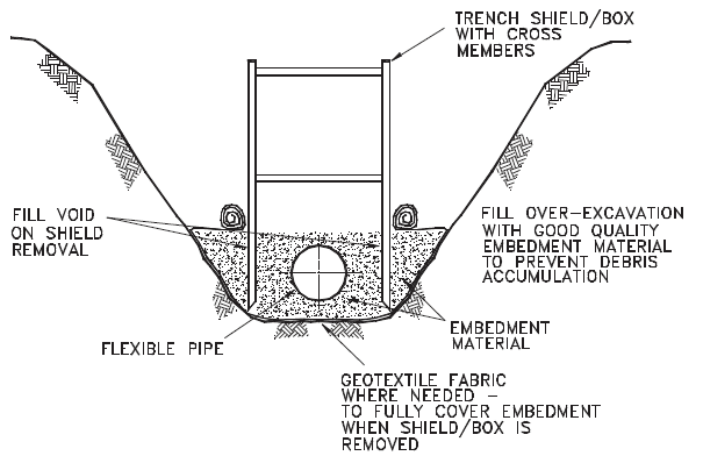
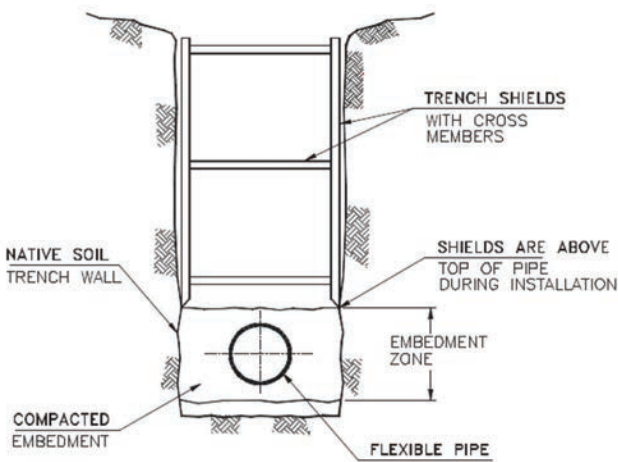

FIGURE 4.4 Shields in wide trench

FIGURE 4.2 Shields kept above side support



4.7 PIPE LAYING

4.7.1 BEDDING

The bedding material must be the same as the embedment used to surround the pipe. Its purpose is to provide uniform support and load distribution underneath the pipe barrel, the remaining embedment material and the backfill.

A layer of embedment material must be placed and compacted as the bedding. The bedding thickness must be a minimum of 100mm for pipe sizes DN225 to DN375 and 150mm for sizes DN450 to DN1200 or as specified. A small depression must be formed under each socket to ensure that the pipe barrel is evenly supported along its entire length. When laid to the specified alignment the pipes must be at the centreline of the trench.

If groundwater is present, the trench must be drained so that the pipes can be joined and installed in relatively dry conditions. In low strength soils, additional bedding material will be required as a replacement for unsatisfactory native material in the foundation zone.



BlackMax pipes lowered into the trench with a nylon sling



Granular material spread evenly in the trench

4.7.2 JOINTING OF PIPES

Once the trench and bedding has been prepared, pipes can be lowered into the trench with the aid of suitable slings or ropes. Chains must not be used to avoid potential slippage between the pipe and chains. Manual handling and lifting is possible with most BlackMax pipe sizes. Refer to your local safe handling work practices and guidelines when handling pipes and weights referenced in Table 2.2 for guidance. Alternatively, an excavator can be used with a nylon sling at the pipe mid-point.

The following rubber ring joint procedure is required for the quality assembly of the BlackMax pipe joint pipes:

1. Clean the pipe socket and spigot grooves, making sure both are free of soil and foreign material.

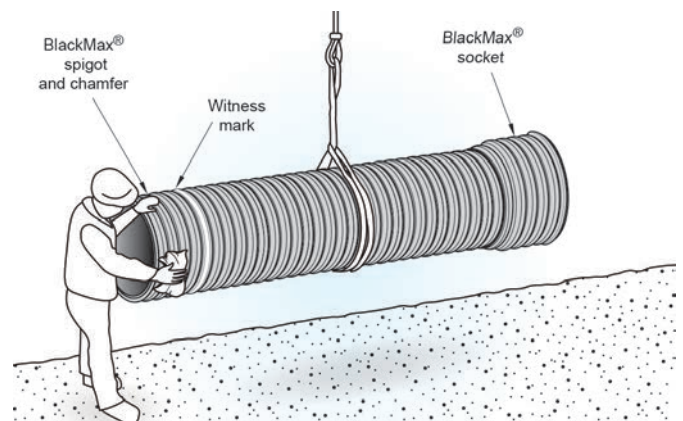
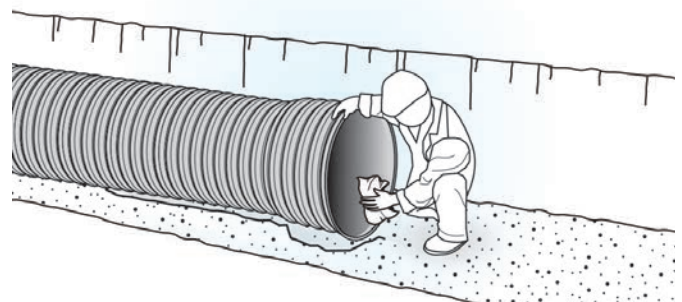

All images are indicative only and not to scale.

2. Clean the rubber ring seal and ensure the ring is free from any soil and foreign matter. Install the rubber ring by stretching it over the spigot in the second trough from the end of the pipe. Ensure the rubber ring sits evenly inside the trough by running your hands and fingers around its full circumference.

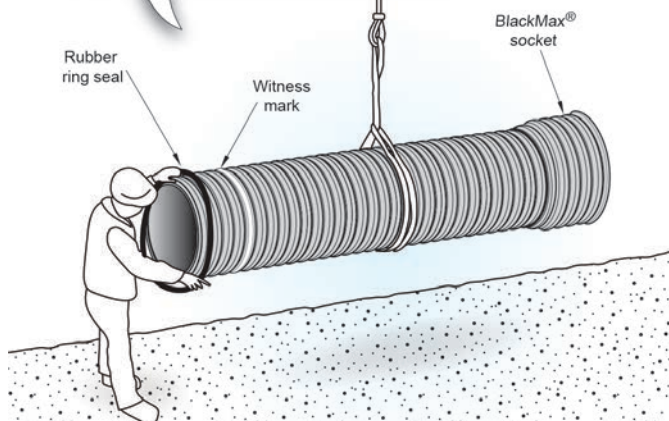
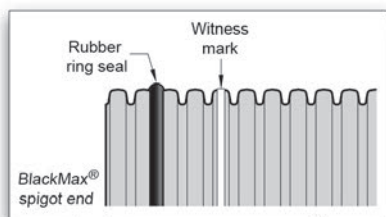
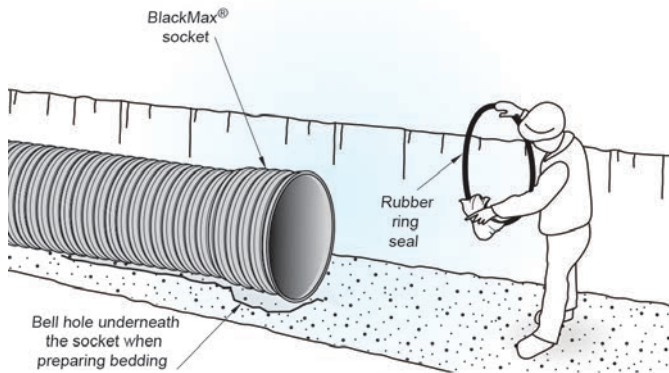

3. Although pipes may show some out-of-roundness due to storage loads, this is usually minimal. Where it is present, it is advantageous to orientate the larger pipe diameter in the vertical plane. This will ease the jointing process and helps offset any deflection after backfilling.

4. Apply Iplex pipe jointing lubricant liberally to the inside of the socket and lead-in flare. Avoid lubricating the ring itself to ensure it does not pick up dirt while the joint is being

made. (MINERAL OILS OR GREASES MUST NOT BE USED UNDER ANY CIRCUMSTANCES, AS THESE COMPOUNDS WILL CAUSE LONG-TERM DEGRADATION OF THE RUBBER SEAL. IN AN EMERGENCY COMMON SOAP CAN BE USED). Only use pipe lubricants in accordance with the manufacturer's directions.

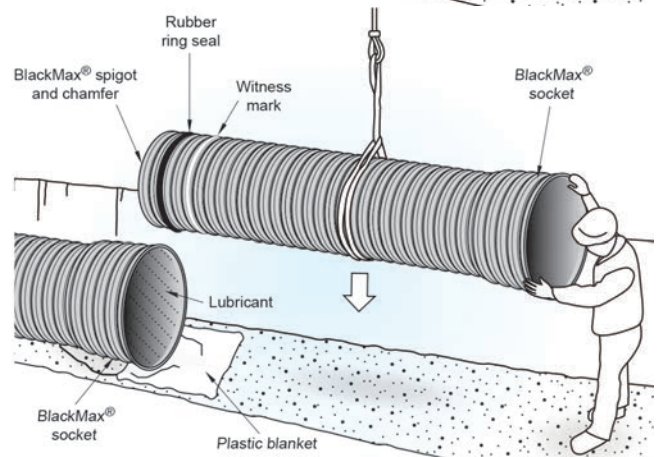
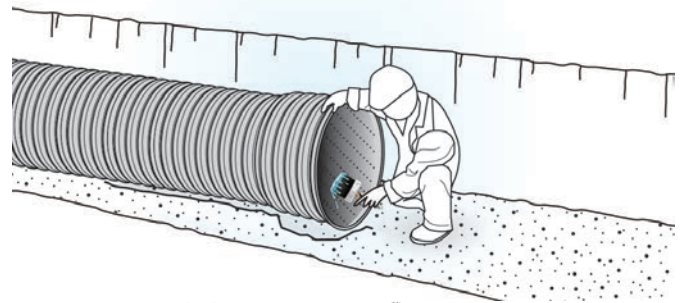

5. Insert the leading edge of the spigot into the socket mouth. It is essential that pipes are aligned in a straight line before attempting to make the joint.

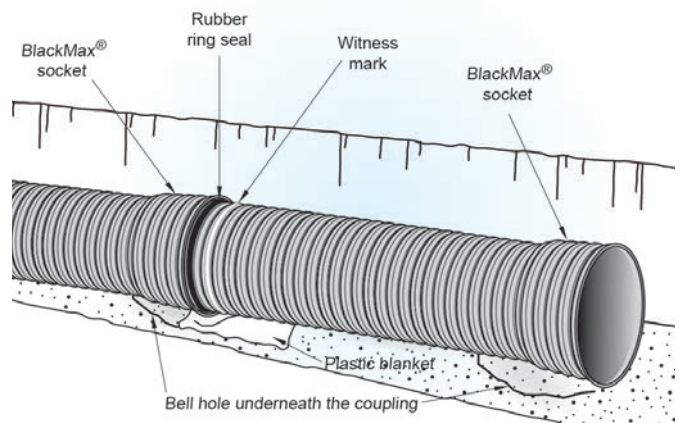

The normal convention is to lay pipes by starting from the down-stream end with the socket facing in the up-stream direction. After laying, pipes must be held in position to line and grade by placing enough embedment material over each pipe before joining the next one.

All images are indicative only and not to scale.

6. Apply force evenly on a timber-bridging piece protecting the end of the pipe.
7. Push home to the spigot witness mark.

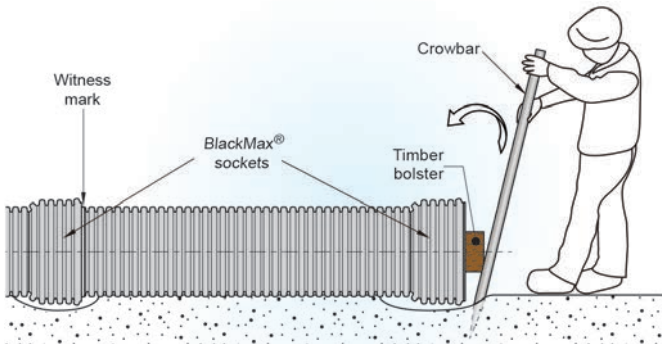

Generally smaller pipes can be pushed home with a crowbar.

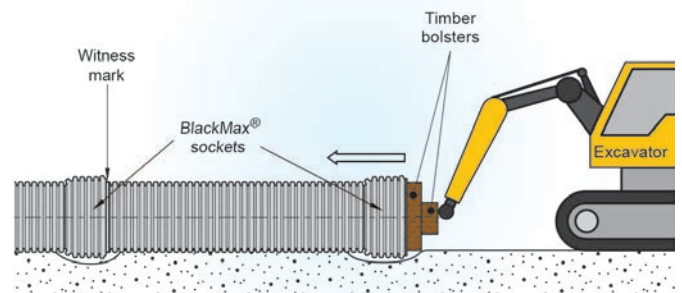

Larger pipes require mechanical force during the jointing procedure.

4.7.2.1 PIPE CUTTING

BlackMax pipes can be cut anywhere along their length as required. Always ensure that safe work practices are observed and wear appropriate PPE, such as impact resistant Type F gloves. The cut must be made in the valley between the corrugations at right angles to the axis of the pipe. No end treatment or chamfer is required. BlackMax pipes can be safely cut using any saw suitable for cutting timber. This can be a manual or powered saw.

IMPORTANT SAFETY INFORMATION: When using saws ensure the pipe is secure and stable from any movement. Both hands must be on the saw, not the pipe, as saws can bounce and lacerate a guiding hand. After cutting the pipe, it is important to place a new witness mark at the end of the spigot at a distance shown in Tables 2.2. Then repeat steps 1 to 7 in section 4.7.2.

4.8 PIPE SIDE SUPPORT AND OVERLAY

4.8.1 EMBEDMENT - HAUNCHING AND SIDE SUPPORT

Material used in the embedment zone should be uniform selected non cohesive soils. Information regarding selection is given in Appendices G and H of AS/NZS 2566.2.

The embedment must be evenly compacted between the pipe and the surrounding native soil given that the complete side support zone extends horizontally beyond the pipe for approximately twice the pipe diameter at pipe depth. Care must be taken not to disturb the pipe alignment when compacting the embedment material.

Where trench shields or boxes are used, special care is necessary to fill any voids resulting from their removal and must be filled with the same compacted embedment material.

If there is a possibility of migration of fines between the embedment and native soil, geotextile fabric must be used at the interface to completely envelope the embedment including the bedding. Refer to Section 4 and Appendix J of AS/NZS 2566.2 for further information.

Attention to the quality and degree of compaction of the embedment material placed on each side of a BlackMax pipeline is fundamental to its structural integrity. Table 4.2 shows the default values given in AS/NZS 2566.2 for the appropriate degree of relative compaction of the embedment bedding and side support zone.

All images are indicative only and not to scale.

TABLE 4.2 Minimum relative compactions (AS/NZS2566.2)

Soil Types	Test Method	Trafficable areas		Non trafficable areas	
		Embedment material %	Trench / embankment fill material %	Embedment material %	Trench / embankment fill material %
Cohesionless	Density Index	70	70	60	Compaction to suit site requirements
Cohesion	Standard Dry Density Ratio, or Hilt Density Ratio	95	95	90	

4.8.2 OVERLAY

The embedment material must extend to a cover height of 150mm (DN225 to DN750) and 200mm (DN900 to DN1200) above the pipe to provide protection from the placement of overburden material. For minimum cover heights above pipe during the operation of compaction equipment, see Table 3.8.

4.9 TRENCH & EMBANKMENT FILL

Backfilling the pipeline may involve the use of the excavated material. Ensure the thickness of the overlay is adequate. Care must be taken to avoid the inclusion of large stones, rocks or hard clumps that may cause point loading on the pipeline.

Overburden compaction with large vibrating power compactors must be avoided until there is adequate height of fill over the pipe (Refer to Section 3.2.4). This will vary depending on the capacity of the machine used.

4.9.1 MONITORING DIAMETRAL DEFLECTIONS

Once the backfilling operation is complete, the adequacy of the embedment and compaction and the use of correct

backfilling techniques may be assessed by measuring the vertical deflection within the pipe. The deflection check described in Section 5.1 is useful in the initial construction period as this provides an opportunity for bench-marking appropriate compaction procedures.

Maximum allowable initial deflection values are given in AS/NZS 2566.2 for differing time intervals after completion of the fill operation e.g. the maximum allowable deflection at 24 hours is 3.5 % and at 30 days 5.0 %. Refer to Table 5.1.

Note: Compaction of the embedment in the pipe embedment zone may increase the vertical pipe diameter and decrease the horizontal pipe diameter. This is not detrimental, providing the magnitude of the horizontal diametrical deformation does not exceed the prescribed allowable deflections. See Section 5.2 for test procedure.

4.10 BORE CASING

When BlackMax pipes are used to re-line a failed non pressure pipe, skids or approved spacers must be used to prevent damage to the pipe and socket joints during installation.

They must properly position the pipe in the casing. Figure 4.5 shows a typical arrangement of spacers assembled on BlackMax pipes ready for installation.

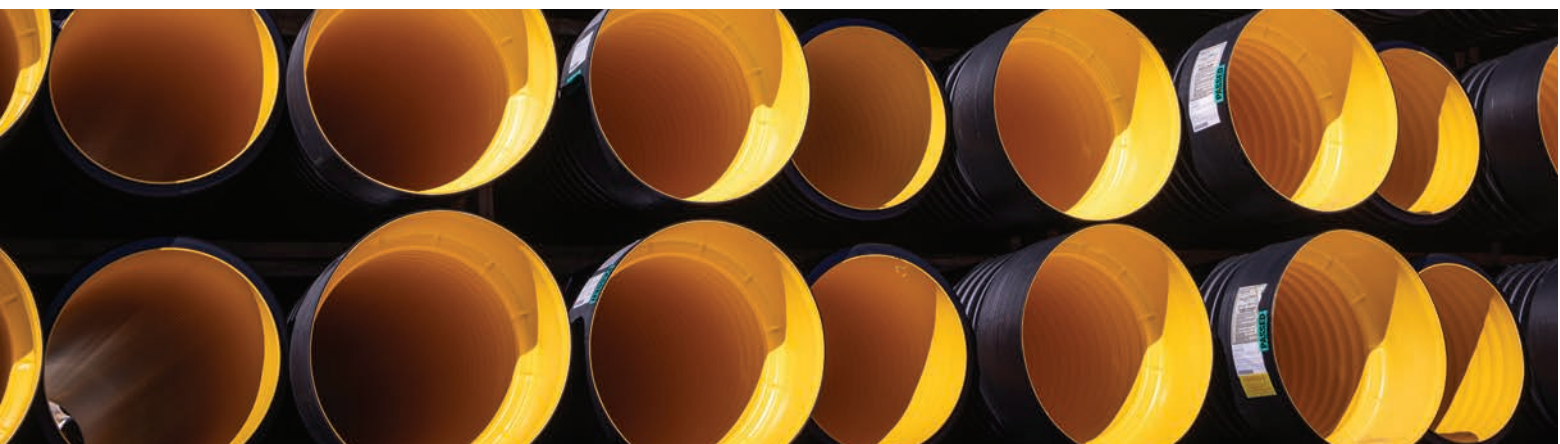

FIGURE 4.5 Approved Plastic Spacer Arrangement for BlackMax pipes



Spacers must be assembled in accordance with the manufacturer’s recommendations. Skids must extend for the full length of the pipe, except for the socket and spigot (up to the witness mark). Spacers or skids must provide enough height to permit clearance between the pipe socket and casing wall. Casings are normally sized to provide an inside diameter which is at least 50mm greater than the Maximum outside diameter of the pipe socket, spacers or skids, whichever is the greatest.

Skids or spacers must be fastened securely to the pipe. Use Iplex pipe lubricant between the skids and casing for ease of installation. Upon completion of pipe insertion, grouting of the void in accordance with design requirements can be accomplished.

For further information with lengths and maximum loading contact Iplex.

4.10.1 GROUTING

Where it is necessary to pressure grout an annulus between the pipe and enveloping conduit, it is important to ensure that the grout is introduced into the annulus evenly. The pipe must be properly restrained to resist flotation, deformation and bending. In addition, the hydrostatic grout pressure must not exceed 70kPa to ensure there is an adequate factor of safety against buckling instability. If necessary, the effect of grout pressures can be nearly halved by filling the pipeline with water. Alternatively, it may be possible to stage the grouting process in two or three lifts, allowing the grout to solidify in the annulus below the spring-line before the top section is filled. This method is illustrated in Appendix K of AS/NZS 2566.2.

4.11 JOINTING TO RIGID STRUCTURES

4.11.1 RELATIVE SETTLEMENT

BlackMax pipes can be directly embedded into concrete pits, or other concrete structures.

FIGURE 4.6 Typical connection to a concrete stormwater pit with BlackMax pipe.

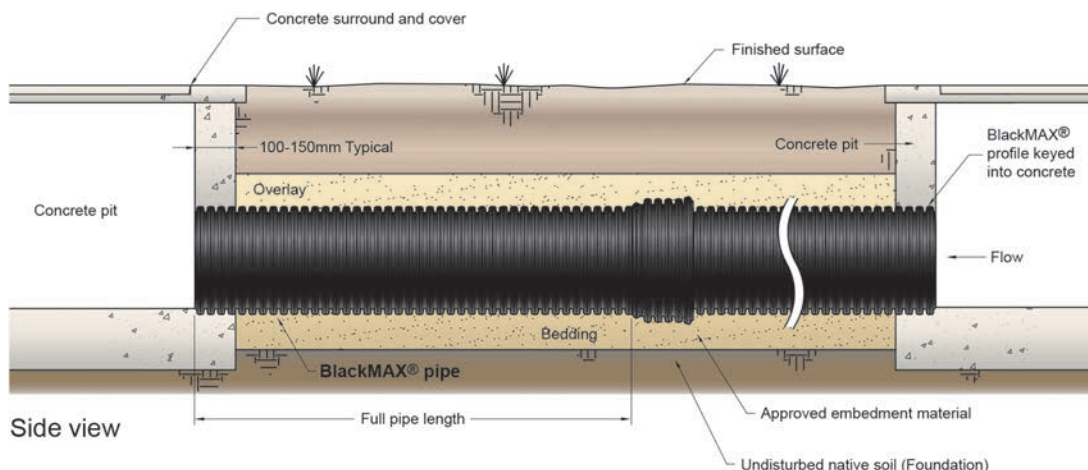

All images are indicative only and not to scale.

4.11.2 CONNECTIONS FOR INCOMING SIDELINES (NON-PRESSURE)

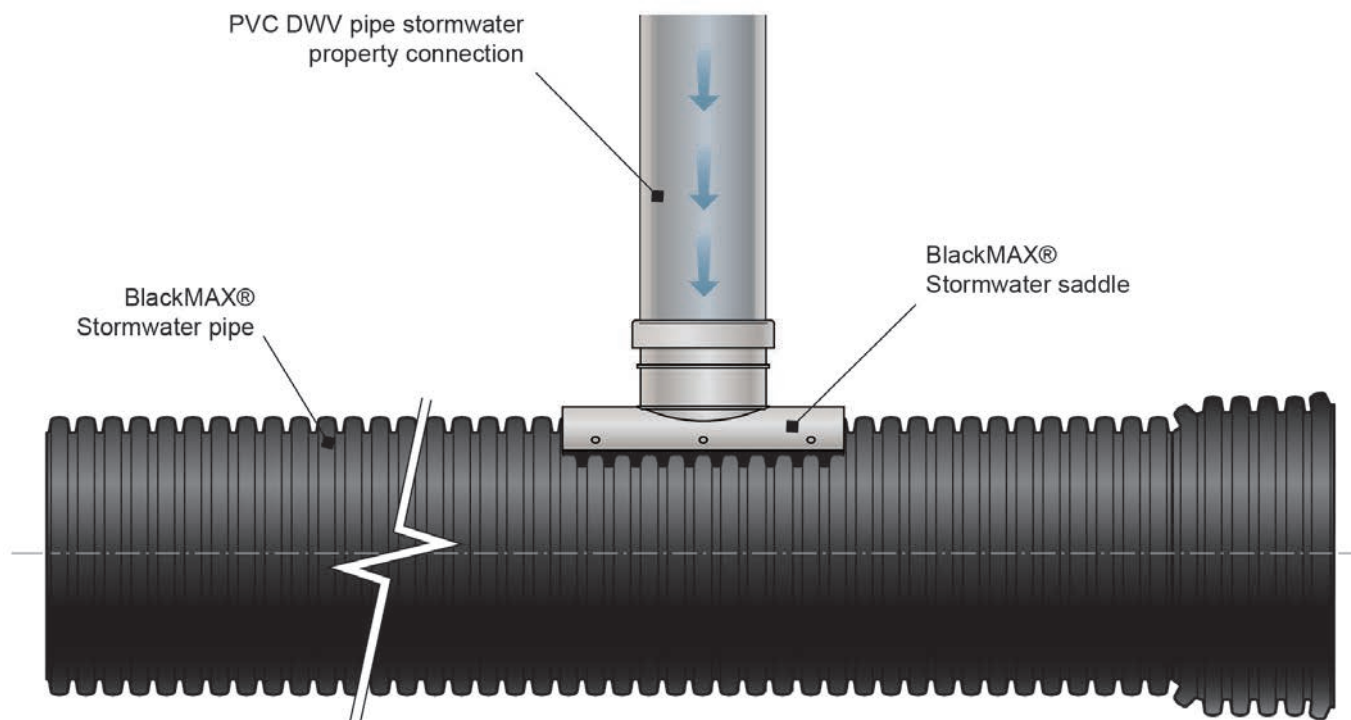

All images are indicative only and not to scale.

BlackMax stormwater saddles with dn100 and dn150 DWV PVC branch off-takes are available for stormwater drainage inflow connections. These saddles include a solid wall ribbed gasket, which provides a precision fit with BlackMax pipes. The procedure for installing the stormwater saddle is as follows:

1. Place the saddle at the required position on the pipe. Note that, the profile gasket will guide the saddle onto the pipe and ensure the saddle sits correctly.
2. Using the saddle as a template, inscribe a circle on the pipe with a marker corresponding with the off-take diameter.
3. Remove the saddle and position the pilot drill of the hole-saw at the centre of the circle and cut the hole.
4. Apply a bead of butyl mastic on the underside of the saddle.
5. Place the saddle in position and secure with the fasteners supplied.

4.12 REPAIR METHODS

The condition and size of the damaged area is important to determine the type of repair needed.

4.12.1 FOR MINOR REPAIRS

If the damage is minor or small in the pipe wall, then it may be repaired by using a BlackMax repair clamp (Refer to Section 2.4.5 Product Codes C37018...).

The repair clamp can be wrapped around the pipe at the point of damage with minimal disturbance to the pipeline. The profile ribbed gasket is preformed to match the external pipe wall profile and provides a watertight seal. The pipe surface profiles must be clean and free of dirt, mud and any foreign matter prior to installing the repair clamp.

The procedure for installation is as follows:

1. Loosen all nuts on the clamp, but do not remove from the studs. Slide the locking plate towards the nuts and open the clamp.
2. Position the clamp centrally over the damaged area ensuring that no foreign matter will be trapped between the

matting surfaces. Special attention must be given to cleaning the troughs in the pipe profile.

3. Wrap the clamp around the pipe and bring both ends together by using the locking washer plate.
4. Lock into place and squeeze the lugs together while tightening the nuts by hand. Prior to tightening the nuts with a torque wrench, ensure the damaged area is correctly centred under the clamp.
5. Tighten the nuts with the torque wrench to the required torque as indicated by the installation instructions attached to the clamp.
6. Re-establish the specified embedment material in the embedment zone and backfill to the required standard and compaction.

4.12.2 MAJOR REPAIRS

If damage is severe, then the damaged pipe wall section must be removed and replaced with a new pipe section of the same length. The pipe ends can be joined using BlackMax joining clamps (Refer to section 2.4.5 Product Code C37019 and Figure 4.7). The BlackMax joining clamps and shear banded couplings are comprised of a stainless-

steel shell with a flat rubber sleeve and utilise two BlackMax sealing rings to make the joint.

The procedure for installation is as follows:

1. Locate and expose the whole length of the damaged pipe.
2. Cut and remove the damaged pipe section. Cut the pipes in the trough of the pipe at both ends, using a hand saw or circular disc.
3. Clean and trim the intact pipe ends, leaving these ends smooth and square.
4. Cut a length of replacement pipe of the same distance between the prepared ends less the length of a single profile.
5. Fit the BlackMax rubber rings on each pipe end. These rings must be placed in the first trough from each pipe end (Figure 4.7).
6. Fit the clamps symmetrically over each joint. Ensure the clamps are positioned centrally over each joint.
7. Tighten the nuts with the torque wrench to the specified torque as labeled on the clamp.
8. Re-establish the embedment and backfill as specified.

FIGURE 4.7 Major BlackMax pipe repair

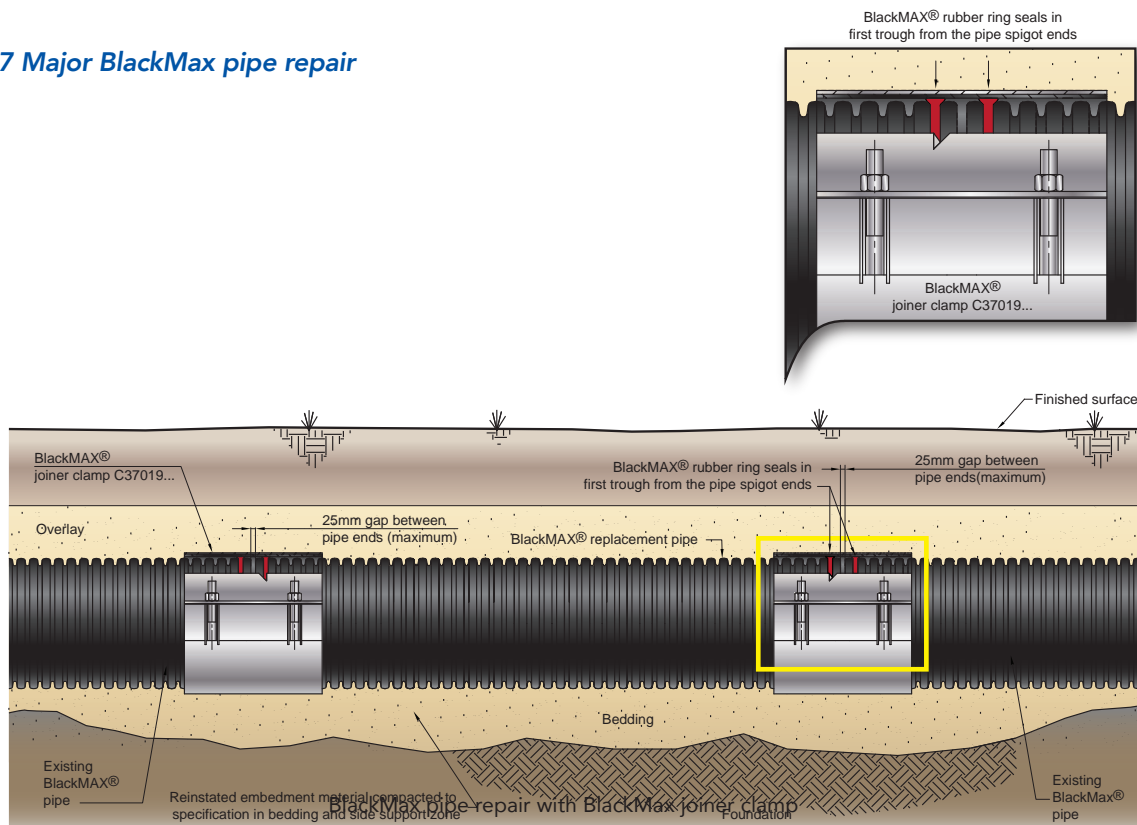

All images are indicative only and not to scale.

4.12.3 MAJOR REPAIRS - FERNCO COUPLING

Equipment required:



1. Locate and expose the damaged area of the pipe.
2. Cut and remove the damaged pipe section. Cut the pipes in the valley of the pipe at both ends. Use a hand saw or circular disc. Ensure the ends are cut square to the pipe axis.



3. Clean and trim the pipe ends. Remove any sharp edges, leaving them smooth.
4. Cut a length of replacement pipe of the same distance between the prepared ends less the length of a single profile.
5. Slide both Fernco couplings over the existing pipe ends.

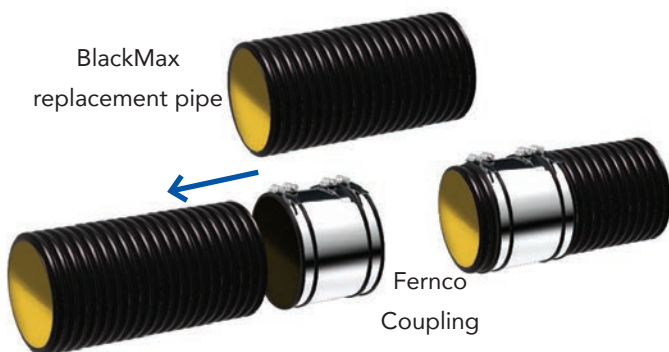

6. Fit the BlackMax rubber rings on each pipe end. These rings must be placed in the first trough from each pipe end. The pipe ends and rings must be clean at all times



7. Ensure the axes of the replacement pipe ends and existing pipe ends are aligned in a straight line. Position the Fernco Couplings over the pipe ends and ensure they are centrally located over the pipe gaps. Tighten the coupling fasteners to the recommended torque and sequence as per the instructions on the coupling.



8. Compact the bedding underneath the repaired pipe section (existing and replacement pipes). Check and retighten the fasteners to the recommended torque prior to placing and compacting the embedment in the side support zone and overlay zone. The trench can now be backfilled as specified.

All images are indicative only and not to scale.

5.0 FIELD ACCEPTANCE TESTING

Field-testing is used for identifying installation problems such as damaged pipes, poor embedment placement and/or compaction and jointing deficiencies. A diametrical deflection check, as the principle indicator can easily assess the structural integrity of a BlackMax pipe and the surrounding embedment and compaction.

5.1 DEFLECTION TESTING

Deflection measurements are often used as additional quality control to indirectly assess the relative compactions achieved during installation and whether the required structural performance has been achieved. A visual line-of-site inspection will usually indicate any abnormal deflections, which must be investigated. An acceptance test may be specified to ensure that the actual short-term vertical deflections do not exceed the allowable deflections given in Table 5.1.

Where actual deflections have exceeded the allowable deflections, the cause must be investigated, and appropriate remedial construction undertaken. This may require the exposure of the affected section of the pipeline and the re-compaction of the side support material without removing pipes.



TABLE 5.1 Maximum allowable deflections by diameter for nominated times after completion of the backfill

		24 hours	3 days	7 days	14 days	30 days	3 months	1 year
Adjustment Factor		0.7	0.75	0.85	0.95	1	1.1	1.2
Deflection (%)		3.5	3.8	4.3	4.8	5.00	5.5	6.0
DN	Pipe ID (mm)	Minimum permissible vertical pipe ID (mm)* at nominated times						
225	225	215	214	213	212	211	210	209
300	300	286	285	284	282	282	280	279
375	373	357	357	355	353	352	350	348
450	447	429	428	426	423	422	420	418
525	522	501	500	497	495	493	491	488
600	596	573	571	568	565	564	561	558
750	736	708	706	702	698	697	693	689
900	877	844	841	837	833	831	826	822
1000	987	950	947	942	937	935	930	925
1200	1170	1127	1123	1117	1111	1109	1103	1097

*Includes a Tolerance of 2.5mm if a proving tool is used



FOR ALL ENQUIRIES AND ORDERS CONTACT IPLEX PIPELINES

WWW.IPLEX.COM.AU

Plumbing and Irrigation **1300 0 IPLEX**

Civil **13 10 86**

Email info@iplexpipelines.com.au

VERSION 2 – JUNE 2025